



HYOSUNG

Made in Korea



GV 650

GT 650

FI service

Kun indsprøjtningssystem 2008

Service manual



SCANDINAVIAN MACHINERY IMPORT ApS

Holtvej 8-10, Høruphav

6470 Sydals

Telefon: +45 73 15 11 00

Fax: +45 73 15 11 01

E-mail: info@scanmi.dk

www.scanmi.dk

CVR: 27 73 31 07

FOREWORD

This manual contains an introductory description on HYOSUNG 『*Aquila650FI*』 & 『*Comet650S/R FI*』 and procedures for its inspection / service and overhaul of its main components.

It covers the differences from Carbure type and please refer to the service manual of 『*Aquila650* (99000-51210)』, 『*Comet650S & Comet650R* (99000-94910)』 and 『*Comet650* (99000-94810)』 for others which are not covered in this manual.

Other information considered as generally known is not included.

Read GENERAL INFORMATION section to familiarize yourself with outline of the vehicle and MAINTENANCE and other sections to use as a guide for proper inspection and service.

This manual will help you know the vehicle better so that you can assure your customers of your optimum and quick service.

- ❖ This manual has been prepared on the basis of the latest specification at the time of publication.
If modification has been made since then, difference may exist between the content of this manual and the actual vehicle.
- ❖ Illustrations in this manual are used to show the basic principles of operation and work procedures.
They may not represent the actual vehicle exactly in detail.

WARNING

This manual is intended for those who have enough knowledge and skills for servicing HYOSUNG vehicles. Without such knowledge and skills, you should not attempt servicing by relying on this manual only.

Instead, please contact your nearby authorized HYOSUNG motorcycle dealer.

GROUP INDEX

GENERAL INFORMATION

1

FI SYSTEM DIAGNOSIS

4-1

FUEL SYSTEM AND THROTTLE BODY

4-2

ELECTRICAL SYSTEM

6

SERVICING INFORMATION

8

 **HYOSUNG**

HOW TO USE THIS MANUAL





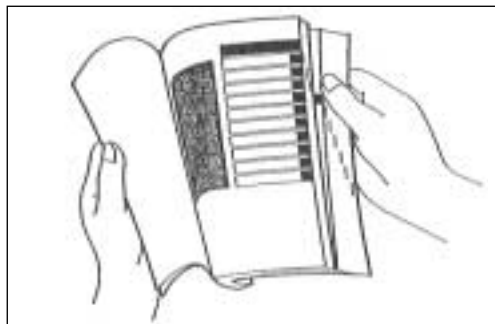











TO LOCATE WHAT YOU ARE LOOKING FOR:

1. The text of this manual is divided into sections.
2. As the title of these sections are listed on the previous page as GROUP INDEX, select the section where you are looking for.
3. Holding the manual as shown at the right will allow you to find the first page of the section easily.
4. On the first page of each section, its contents are listed. Find the item and page you need.



SYMBOL

Listed in the table below are the symbols indicating instructions and other information necessary for servicing and meaning associated with them respectively.

SYMBOL	DEFINITION	SYMBOL	DEFINITION
	Torque control required. Data beside it indicates specified torque.		Apply THREAD LOCK "1324".
	Apply oil. Use engine oil unless otherwise specified.		Apply or use brake fluid.
	Apply SUPER GREASE "A".		Measure in voltage range.
	Apply SUPER GREASE "C".		Measure in resistance range.
	Apply SILICONE GREASE.		Measure in current range.
	Apply MOLY PASTE.		Measure in continuity test range.
	Apply BOND "1215".		Use special tool.
	Use fork oil.		Use engine coolant.

ABBREVIATIONS USED IN THIS MANUAL

A

ABDC	: After Bottom Dead Center
AC	: Alternating Current
API	: American Petroleum Institute
ATDC	: After Top Dead Center

B

BBDC	: Before Bottom Dead Center
BDC	: Bottom Dead Center
BTDC	: Before Top Dead Center

D

DC	: Direct Current
DOHC	: Double Over Head Camshaft

E

ECU	: Engine Control Unit, FI Control Unit
-----	---

F

FI	: Fuel Injection, Fuel Injector
FP	: Fuel Pump

G

GP Switch	: Gear Position Switch
-----------	------------------------

I

IAP Sensor	: Intake Air Pressure Sensor (IAPS)
IAT Sensor	: Intake Air Temperature Sensor (IATS)
IG	: Ignition
ISC Solenoid	: Idle Speed Control Solenoid

L

LCD	: Liquid Crystal Display
LED	: Light Emitting Diode
LH	: Left Hand

M

Max	: Maximum
Min	: Minimum

O

O ₂ Sensor	: Oxygen Sensor (O ₂ S)
-----------------------	------------------------------------

R

RH	: Right Hand
----	--------------

S

SAE	: Society of Automotive Engineers
SAV Solenoid	: Secondary Air Valve Solenoid

T

TDC	: Top Dead Center
TO Sensor	: Tip Over Sensor (TOS)
TP Sensor	: Throttle Position Sensor (TPS)

W

WT Sensor	: Water Temperature Sensor (WTS)
-----------	-------------------------------------

WIRE COLOR

B	: Black	Gr	: Gray	Sb	: Light blue
L	: Blue	Lg	: Light green	W	: White
Br	: Brown	O	: Orange	Y	: Yellow
G	: Green	R	: Red		

BL	: Black with Blue tracer	BBr	: Black with Brown tracer
BG	: Black with Green tracer	BO	: Black with Orange tracer
BR	: Black with Red tracer	BW	: Black with White tracer
BY	: Black with Yellow tracer	LB	: Blue with Black tracer
LG	: Blue with Green tracer	LR	: Blue with Red tracer
LW	: Blue with White tracer	LY	: Blue with Yellow tracer
BrB	: Brown with Black tracer	BrW	: Brown with White tracer
GB	: Green with Black tracer	GR	: Green with Red tracer
GY	: Green with Yellow tracer	GrB	: Gray with Black tracer
GrR	: Gray with Red tracer	GrW	: Gray with White tracer
OB	: Orange with Black tracer	OL	: Orange with Blue tracer
OG	: Orange with Green tracer	OR	: Orange with Red tracer
OW	: Orange with White tracer	OY	: Orange with Yellow tracer
RB	: Red with Black tracer	RW	: Red with White tracer
WB	: White with Black tracer	WL	: White with Blue tracer
WR	: White with Red tracer	YB	: Yellow with Black tracer
YL	: Yellow with Blue tracer	YG	: Yellow with Green tracer
YR	: Yellow with Red tracer		

GENERAL INFORMATION

CONTENTS

SPECIFICATIONS(<i>Aquila650</i> FI & <i>Comet650</i> FI)	6 (1-8-1)
SPECIFICATIONS(<i>Comet650S</i> FI & <i>Comet650R</i> FI)	8 (1-9-1)

SPECIFICATIONS (*Aquila 650 FI* & *Comet 650 FI*)

⊙ DIMENSIONS AND MASS

ITEM	<i>Aquila 650 FI</i>	<i>Comet 650 FI</i>
Overall length	2,430 mm (95.7 in)	2,060 mm (81.1 in)
Overall width	840 mm (33.1 in)	740 mm (29.1 in)
Overall height	1,155 mm (45.5 in)	1,090 mm (42.9 in)
Wheelbase	1,665 mm (65.6 in)	1,435 mm (56.5 in)
Ground clearance	160 mm (6.3 in)	150 mm (5.9 in)
Mass	220 kg (485 lbs)	205 kg (451 lbs)

⊙ ENGINE

ITEM	<i>Aquila 650 FI</i>	<i>Comet 650 FI</i>
Type	Four-stroke, DOHC, Liquid-cooled	←
Number of cylinder	V-2 cylinder	←
Bore	81.5 mm (3.21 in)	←
Stroke	62.0 mm (2.44 in)	←
Piston displacement	647 cm ³ (39.5 in ³)	←
Fuel system	Fuel Injection	←
Starter system	Electric starter	←
Lubrication system	Wet sump	←

⊙ TRANSMISSION

ITEM	<i>Aquila 650 FI</i>	<i>Comet 650 FI</i>
Clutch	Wet multi-plate type	←
Transmission	5-speed constant mesh	6-speed constant mesh
Gearshift pattern	1-down, 4-up	1-down, 5-up
Final reduction	2.79	2.93
Gear ratio, 1st	2.46	2.46
2nd	1.78	1.60
3rd	1.38	1.32
4th	1.13	1.13
5th	0.96	0.96
6th	—	0.85
Drive belt / chain	Poly chain belt	RK525XSO 108 links

◎ CHASSIS

ITEM	<i>Aquila 650 FI</i>	<i>Comet 650 FI</i>
Front suspension	Telescopic type	←
Rear suspension	Swingarm type	←
Steering angle	35 ° (right & left)	30 ° (right & left)
Caster	35 °	25.5 °
Trail	160 mm (6.3 in)	85 mm (3.35 in)
Front brake	Double disk brake	←
Rear brake	Disk brake	←
Front tire size	120/70 - ZR 18 59W	120/60 - ZR 17 55W
Rear tire size	180/55 - ZR 17 73W	160/60 - ZR 17 69W
Front fork stroke	130 mm (5.12 in)	120 mm (4.72 in)

◎ ELECTRICAL

ITEM	<i>Aquila 650 FI</i>	<i>Comet 650 FI</i>	
Ignition type	ECU	←	
Ignition timing	5 ° B.T.D.C.at 1,500 rpm	←	
Spark plug	CR8E	←	
Battery	12 V 12 Ah (MF)	←	
Fuse	Main	30 A	←
	Head lamp	15 A	←
Head lamp	HI	12 V - 60 W × 1	12 V - 60 W × 1
	LO	12 V - 55 W × 1	12 V - 55 W × 1
Turn signal lamp	12 V - 10 W × 4	12 V - 10 W × 4	
Brake / Tail lamp	LED type	12 V - 21 / 5 W × 1	
Illumination lamp	-	LED type	
License plate lamp	12 V - 5 W × 1	12 V - 5 W × 1	
High beam indicator lamp	LED type	LED type	
Turn signal indicator lamp(right & left)	LED type	LED type	
Neutral indicator lamp	LED type	LED type	
Fuel indicator lamp	LED type (Level type)	LED type (Level type)	
Coolant temperature indicator lamp	LED type (Level type)	LED type (Level type)	
"FI"(Fuel Injection) check lamp	LED type	LED type	

◎ CAPACITIES

ITEM	<i>Aquila 650 FI</i>	<i>Comet 650 FI</i>
Fuel tank	16.0 l	17.0 l
Engine oil, oil change	3,000 ml	←
with filter change	3,200 ml	←
overhaul	3,400 ml	←
Front fork oil capacity(One side)	420 cc	380 cc

NOTE

The specifications are subject to change without notice.

SPECIFICATIONS (*Comet 650 S FI* & *Comet 650 R FI*)

⊙ DIMENSIONS AND MASS

ITEM	<i>Comet 650 S FI</i> (Standard type)	<i>Comet 650 S FI</i> (Sport type)	<i>Comet 650 R FI</i>
Overall length	2,060 mm (81.1 in)	←	←
Overall width	740 mm (29.1 in)	655 mm (25.8 in)	←
Overall height	1,125 mm (44.3 in)	←	←
Wheelbase	1,435 mm (56.5 in)	←	←
Ground clearance	150 mm (5.9 in)	←	130 mm (5.1 in)
Mass	215 kg (474 lbs)	←	220 kg (485 lbs)

⊙ ENGINE

ITEM	<i>Comet 650 S FI</i> (Standard type)	<i>Comet 650 S FI</i> (Sport type)	<i>Comet 650 R FI</i>
Type	Four-stroke, DOHC, Liquid-cooled	←	←
Number of cylinder	V-2 cylinder	←	←
Bore	81.5 mm (3.21 in)	←	←
Stroke	62.0 mm (2.44 in)	←	←
Piston displacement	647 cm ³ (39.5 in ³)	←	←
Fuel system	Fuel Injection	←	←
Starter system	Electric starter	←	←
Lubrication system	Wet sump	←	←

⊙ TRANSMISSION

ITEM	<i>Comet 650 S FI</i> (Standard type)	<i>Comet 650 S FI</i> (Sport type)	<i>Comet 650 R FI</i>
Clutch	Wet multi-plate type	←	←
Transmission	6-speed constant mesh	←	←
Gearshift pattern	1-down, 5-up	←	←
Final reduction	2.93	←	←
Gear ratio, 1st	2.46	←	←
2nd	1.60	←	←
3rd	1.32	←	←
4th	1.13	←	←
5th	0.96	←	←
6th	0.85	←	←
Drive chain	RK525XSO 108 links	←	←

◎ CHASSIS

ITEM	<i>Comet650S FI</i> (Standard type)	<i>Comet650S FI</i> (Sport type)	<i>Comet650R FI</i>
Front suspension	Telescopic type	←	←
Rear suspension	Swingarm type	←	←
Steering angle	27 ° (right & left)	←	←
Caster	25.5 °	←	←
Trail	74 mm (2.91 in)	←	←
Front brake	Double disk brake	←	←
Rear brake	Disk brake	←	←
Front tire size	120/60 - ZR 17 55W	←	←
Rear tire size	160/60 - ZR 17 69W	←	←
Front fork stroke	120 mm (4.72 in)	←	←

◎ ELECTRICAL

ITEM	<i>Comet650S FI</i> (Standard type)	<i>Comet650S FI</i> (Sport type)	<i>Comet650R FI</i>
Ignition type	ECU	←	←
Ignition timing	5 ° B.T.D.C.at 1,500 rpm	←	←
Spark plug	CR8E	←	←
Battery	12 V 12 Ah (MF)	←	←
Fuse	Main	30 A	←
	Head lamp	15 A	←
Head lamp	HI	12 V - H1 : 55 W × 1	←
	LO	12 V - H3 : 55 W × 1	←
Turn signal lamp	12 V - 10 W × 4	←	←
Brake / Tail lamp	12 V - 21/5 W × 1	←	←
Illumination lamp	LED type	←	←
License plate lamp	12 V - 5 W × 1	←	←
High beam indicator lamp	LED type	←	←
Turn signal indicator lamp(right & left)	LED type	←	←
Neutral indicator lamp	LED type	←	←
Fuel indicator lamp	LED type (Level type)	←	←
Coolant temperature indicator lamp	LED type (Level type)	←	←
"FI"(Fuel Injection) check lamp	LED type	←	←

◎ CAPACITIES

ITEM	<i>Comet650S FI</i> (Standard type)	<i>Comet650S FI</i> (Sport type)	<i>Comet650R FI</i>
Fuel tank	17.0 l	←	←
Engine oil, oil change	3,000 ml	←	←
with filter change	3,200 ml	←	←
overhaul	3,400 ml	←	←
Front fork oil capacity(One side)	380 cc	←	←

NOTE

The specifications are subject to change without notice.

FI SYSTEM DIAGNOSIS

CONTENTS

PRECAUTIONS IN SERVICING	12 (4-1-1)
FI SYSTEM TECHNICAL FEATURES	16 (4-1-5)
SELF-DIAGNOSIS FUNCTION	22 (4-1-11)
FI SYSTEM TROUBLESHOOTING	25 (4-1-14)
CUSTOMER COMPLAINT ANALYSIS	25 (4-1-14)
SELF-DIAGNOSTIC PROCEDURES	27 (4-1-16)
SELF-DIAGNOSIS RESET PROCEDURE	27 (4-1-16)
MALFUNCTION CODE AND DEFECTIVE CONDITION	28 (4-1-17)
"C12" PICK-UP COIL CIRCUIT MALFUNCTION	30 (4-1-19)
"C14" TP SENSOR CIRCUIT MALFUNCTION	31 (4-1-20)
"C15" WT SENSOR CIRCUIT MALFUNCTION	34 (4-1-23)
"C17" or "C18" IAP SENSOR CIRCUIT MALFUNCTION	36 (4-1-25)
"C21" IAT SENSOR CIRCUIT MALFUNCTION	38 (4-1-27)
"C22" OXYGEN SENSOR CIRCUIT MALFUNCTION	40 (4-1-29)
"C23" TO SENSOR CIRCUIT MALFUNCTION	41 (4-1-30)
"C24" or "C25" IGNITION COIL MALFUNCTION	42 (4-1-31)
"C31" GP SWITCH CIRCUIT MALFUNCTION	43 (4-1-32)
"C32" or "C33" FUEL INJECTOR CIRCUIT MALFUNCTION	44 (4-1-33)
"C41" FUEL PUMP RELAY CIRCUIT MALFUNCTION	46 (4-1-35)
SENSORS	47 (4-1-36)

4-1

PRECAUTIONS IN SERVICING

When handling the component parts or servicing the FI system, observe the following points for the safety of the system.

⊙ ELECTRICAL PARTS

▣ CONNECTOR / COUPLER

- When connecting a connector, be sure to push it in until a click is felt.
- With a lock type coupler, be sure to release the lock when disconnecting, and push it in fully till the works when connecting it.
- When disconnecting the coupler, be sure to hold the coupler body and do not pull the lead wires.
- Inspect each terminal on the connector / coupler for looseness or bending.
- Inspect each terminal for corrosion and contamination.
The terminals must be clean and free of any foreign material which could impede proper terminal contact.
- Inspect each lead wire circuit for poor connection by shaking it by hand lightly. If any abnormal condition is found, repair or replace.
- When taking measurements at electrical connectors using a tester probe, be sure to insert the probe from the wire harness side (backside) of the connector / coupler.

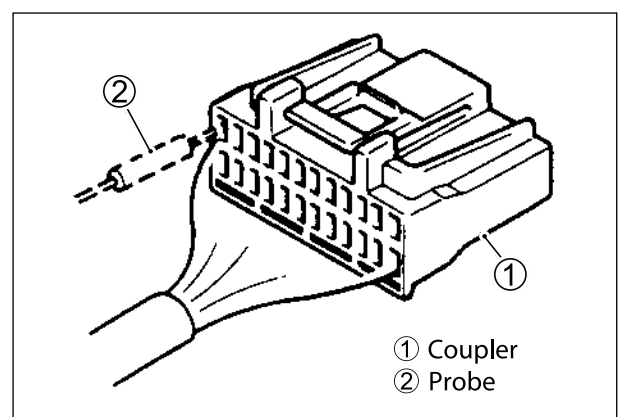
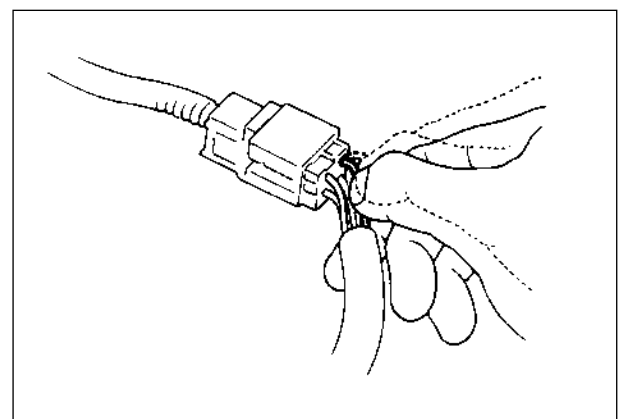
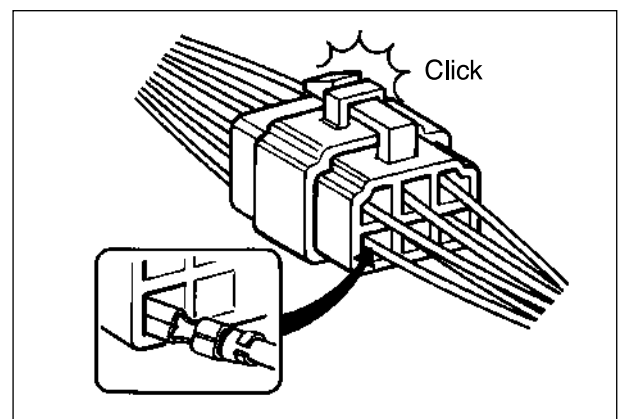
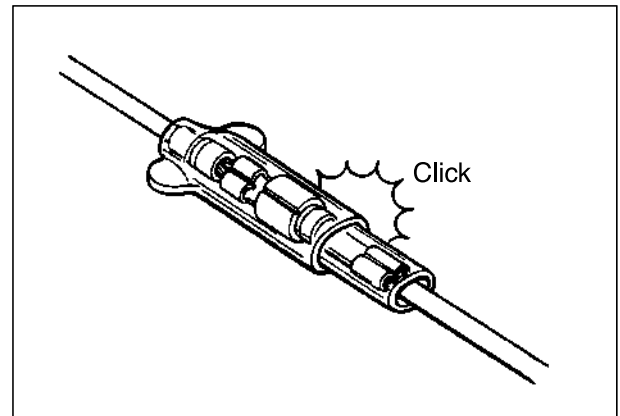

- When connecting meter probe from the terminal side of the coupler (connection from harness side not being possible), use extra care not to force and cause the male terminal to bend or the female terminal to open.

Connect the probe as shown to avoid opening of female terminal.

Never push in the probe where male terminal is supposed to fit.

- Check the male connector for bend and female connector for excessive opening. Also check the coupler for locking (looseness), corrosion, dust, etc.

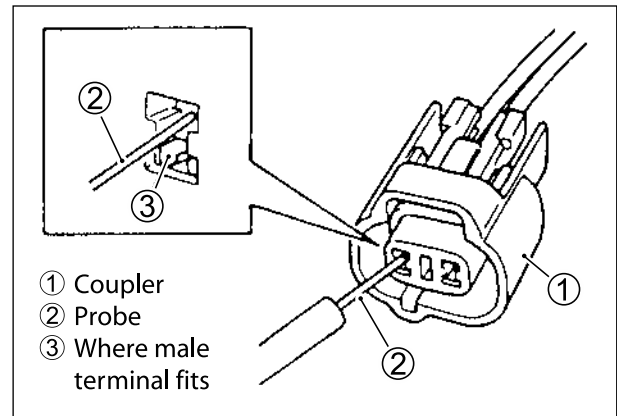

⦿ FUSE

- When a fuse blows, always investigate the cause to correct it and then replace the fuse.
- Do not use a fuse of a different capacity.
- Do not use wire or any other substitute for the fuse.

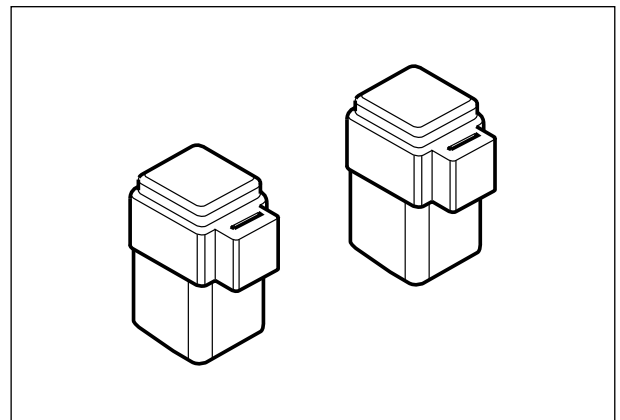

⦿ ECU / VARIOUS SENSORS

- Since each component is a high-precision part, great care should be taken not to apply any sharp impacts during removal and installation.

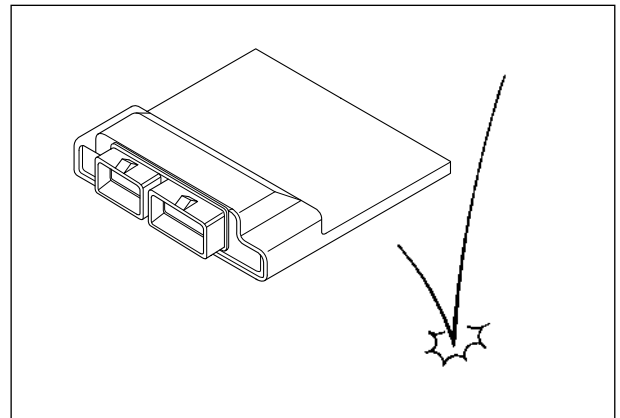

- Be careful not to touch the electrical terminals of the ECU.
The static electricity from your body may damage this part.

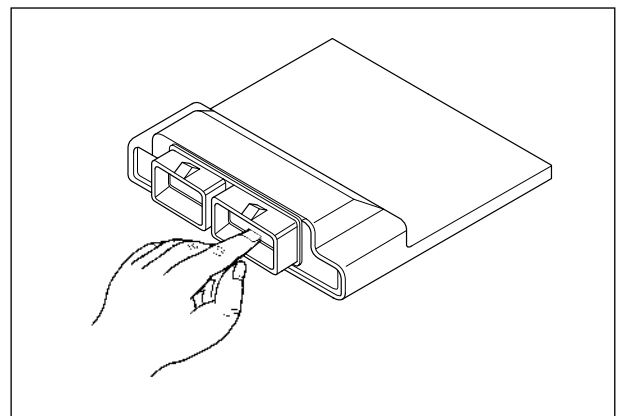

4-1-3 FI SYSTEM DIAGNOSIS

- When disconnecting and connecting the ECU, make sure to turn "OFF" the ignition switch, or electronic parts may get damaged.

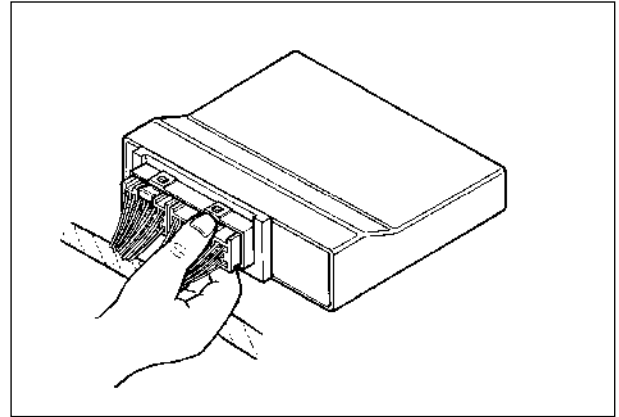

- Battery connection in reverse polarity is strictly prohibited. Such a wrong connection will damage the components of the FI system instantly when reverse power is applied.

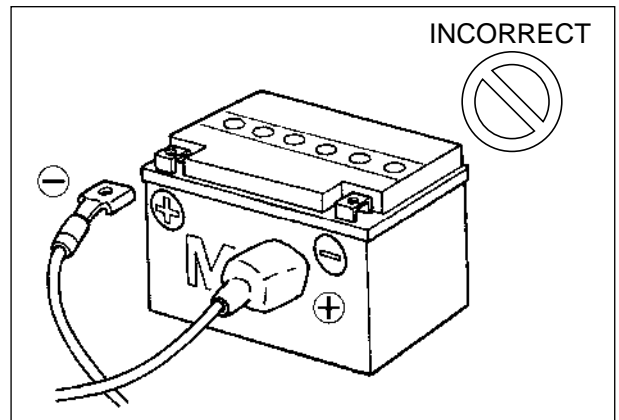

- Removing any battery terminal of a running engine is strictly prohibited. The moment such removal is made, damaging counter electromotive force will be applied to the ECU which may result in serious damage.

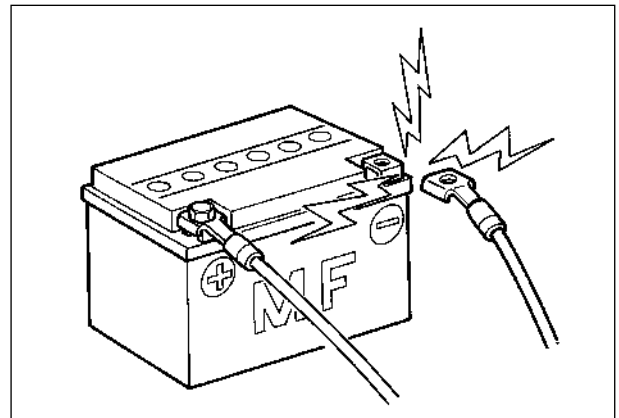

- Before measuring voltage at each terminal, check to make sure that battery voltage is 11V or higher. Terminal voltage check at low battery voltage will lead to erroneous diagnosis.

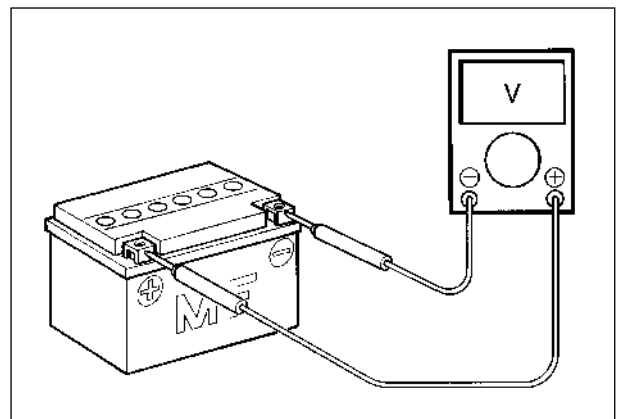

- Never connect an ohmmeter to the ECU with its coupler connected. If attempted, damage to ECU or sensors may result.
- Be sure to use a specified voltmeter / ohmmeter. Otherwise, accurate measurements may not be obtained and personal injury may result.

⊙ USING TESTERS

- Use well-charged batteries in the tester.
- Be sure to set the tester to the correct testing range.

▣ USING THE TESTER

- Incorrectly connecting the ⊕ and ⊖ probes may cause the inside of the tester to burnout.
- If the voltage and current are not known, make measurements using the highest range.
- After using the tester, turn the power off.

FI SYSTEM TECHNICAL FEATURES

◎ INJECTION TIME (INJECTION VOLUME)

The factors to determine the injection time include the basic fuel injection time, which is calculated on the basis of intake air pressure, engine speed and throttle opening angle, and various compensations.

These compensations are determined according to the signals from various sensors that detect the engine and driving conditions.

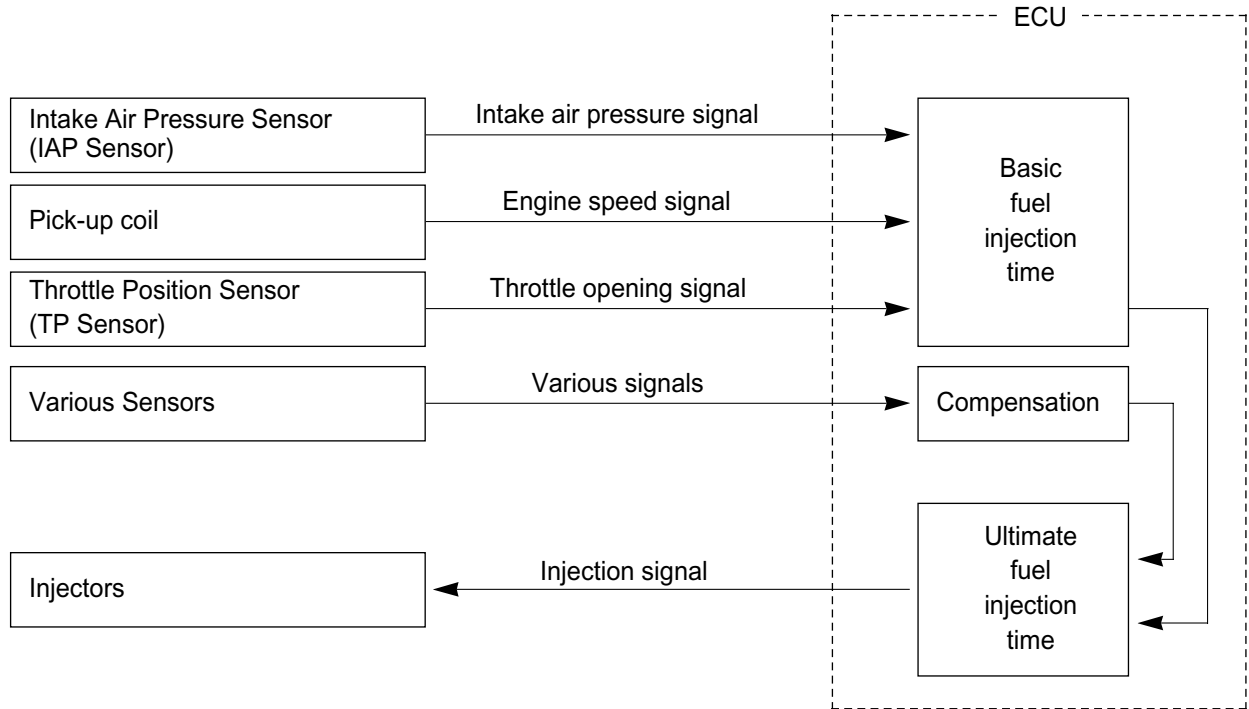

◎ COMPENSATION OF INJECTION TIME (VOLUME)

The following different signals are output from the respective sensors for compensation of the fuel injection time (volume).

SIGNAL	DESCRIPTION
WATER COOLANT TEMPERATURE SENSOR SIGNAL	When engine coolant temperature is low, injection time (volume) is increased.
INTAKE AIR TEMPERATURE SENSOR SIGNAL	When intake air temperature is low, injection time (volume) is increased.
BATTERY VOLTAGE SIGNAL	ECU operates on the battery voltage and at the same time, it monitors the voltage signal for compensation of the fuel injection time (volume). A longer injection time is needed to adjust injection volume in the case of low voltage.
ENGINE RPM SIGNAL	At high speed, the injection time (volume) is increased.
STARTING SIGNAL	When starting engine, additional fuel is injected during cranking engine.
ACCELERATION SIGNAL / DECELERATION SIGNAL	During acceleration, the fuel injection time (volume) is increased in accordance with the throttle opening speed and engine rpm. During deceleration, the fuel injection time (volume) is decreased.

◎ INJECTION STOP CONTROL

SIGNAL	DESCRIPTION
TIP OVER SENSOR SIGNAL (FUEL CUT-OFF)	When the motorcycle tips over, the tip over sensor sends a signal to the ECU. Then, this signal cuts OFF current supplied to the fuel pump, fuel injector and ignition coil.
OVER-REV. LIMITER SIGNAL	The fuel injectors stop operation when engine rpm reaches rev. limit rpm.

◎ FI SYSTEM PARTS LOCATION (*Aquila 650 FI*)

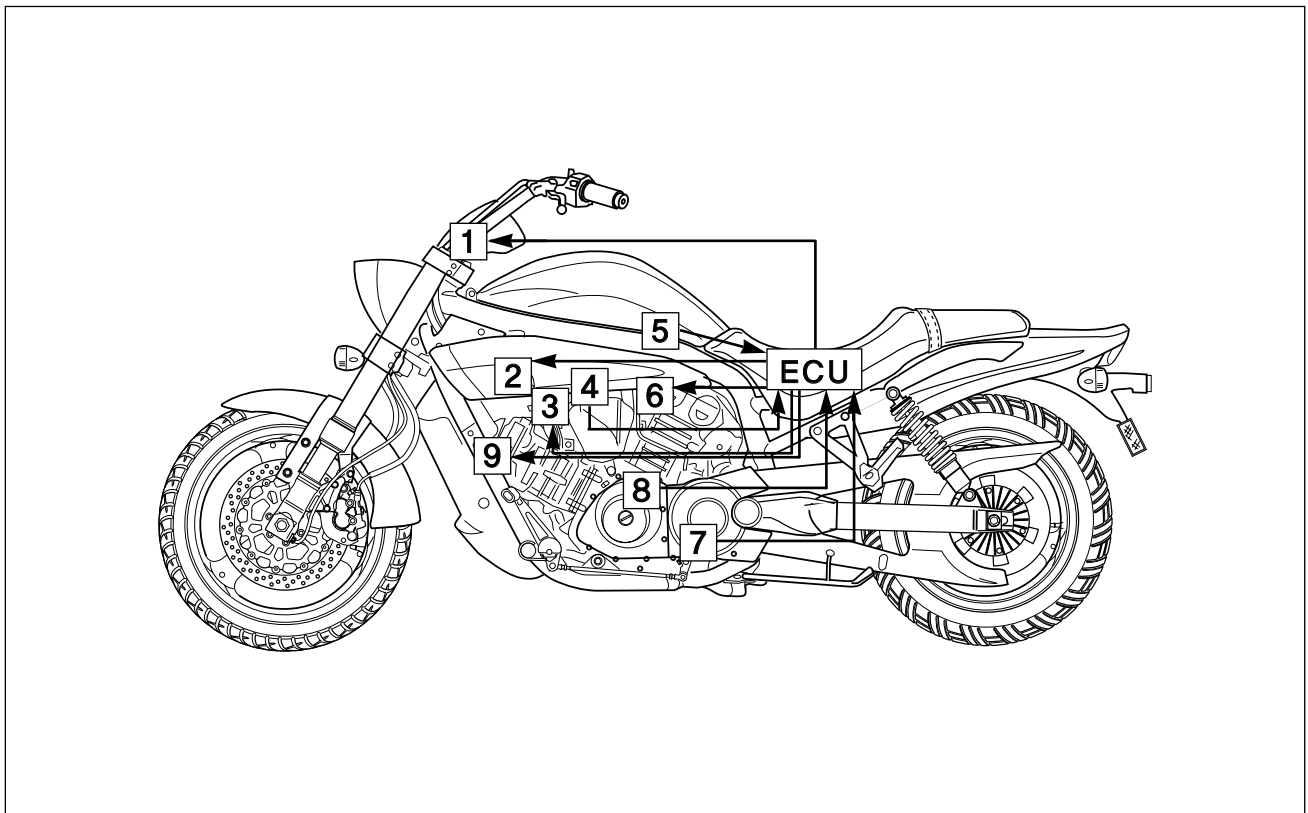

- | | |
|-----------------------|-----------------------|
| ① Speedometer | ⑥ Fuel injector, NO.2 |
| ② Fuel pump relay | ⑦ GP switch |
| ③ Fuel injector, NO.1 | ⑧ Pick-up coil |
| ④ TP sensor | ⑨ Ignition coil, NO.1 |
| ⑤ IAT sensor | |

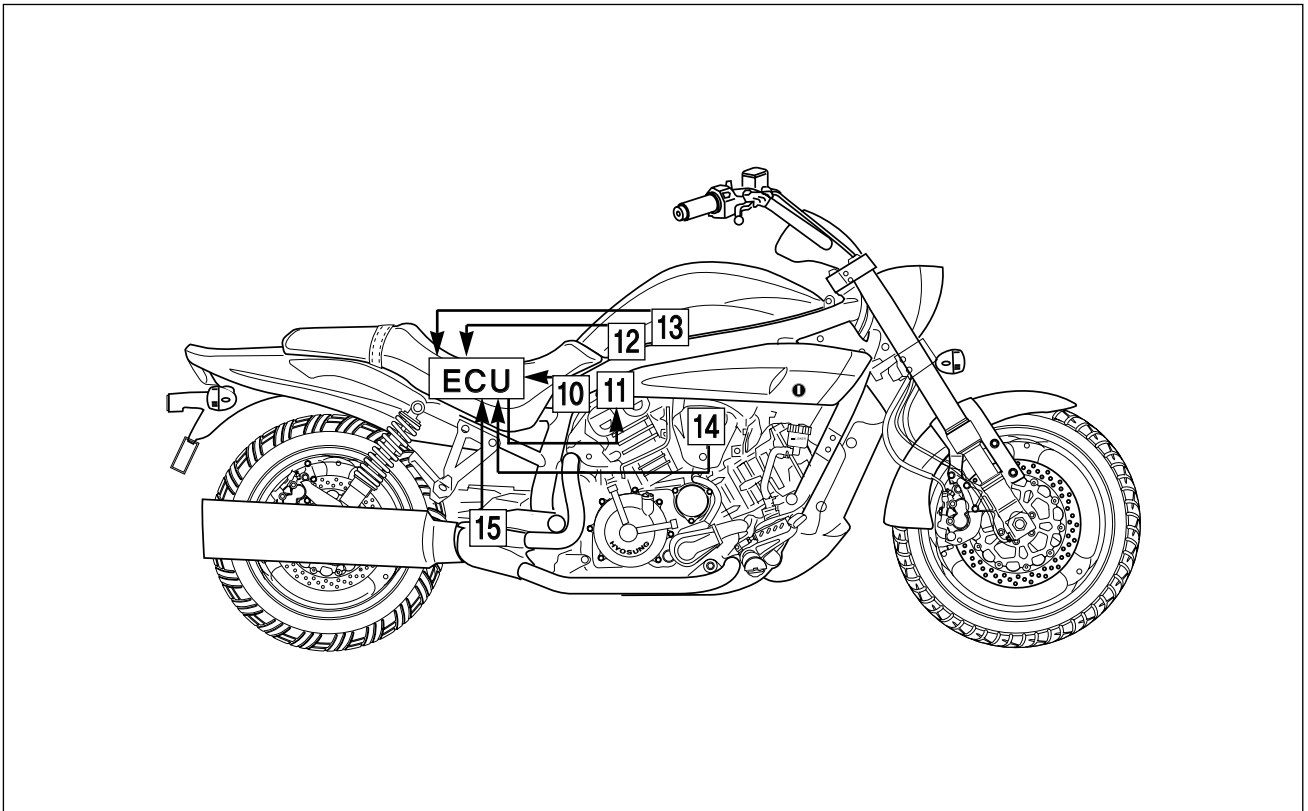

⑩ TO sensor

⑪ Ignition coil, NO.2

⑫ IAP sensor, NO.2

⑬ IAP sensor, NO.1

⑭ WT sensor

⑮ Oxygen sensor

◎ FI SYSTEM PARTS LOCATION (*Comet650/S/R FI*)

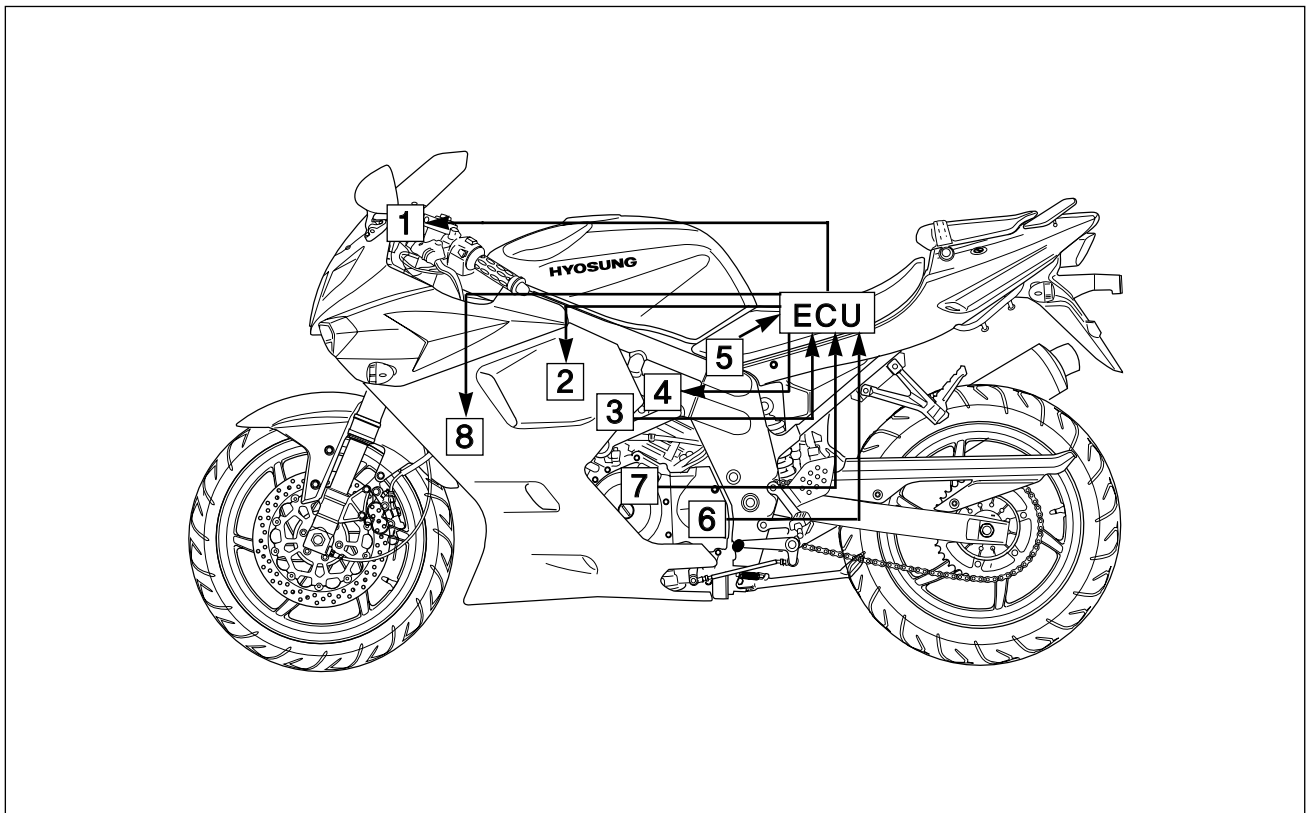

- | | |
|-----------------------|-----------------------|
| ① Speedometer | ⑤ IAT sensor |
| ② Fuel injector, NO.1 | ⑥ GP switch |
| ③ TP sensor | ⑦ Pick-up coil |
| ④ Fuel injector, NO.2 | ⑧ Ignition coil, NO.1 |

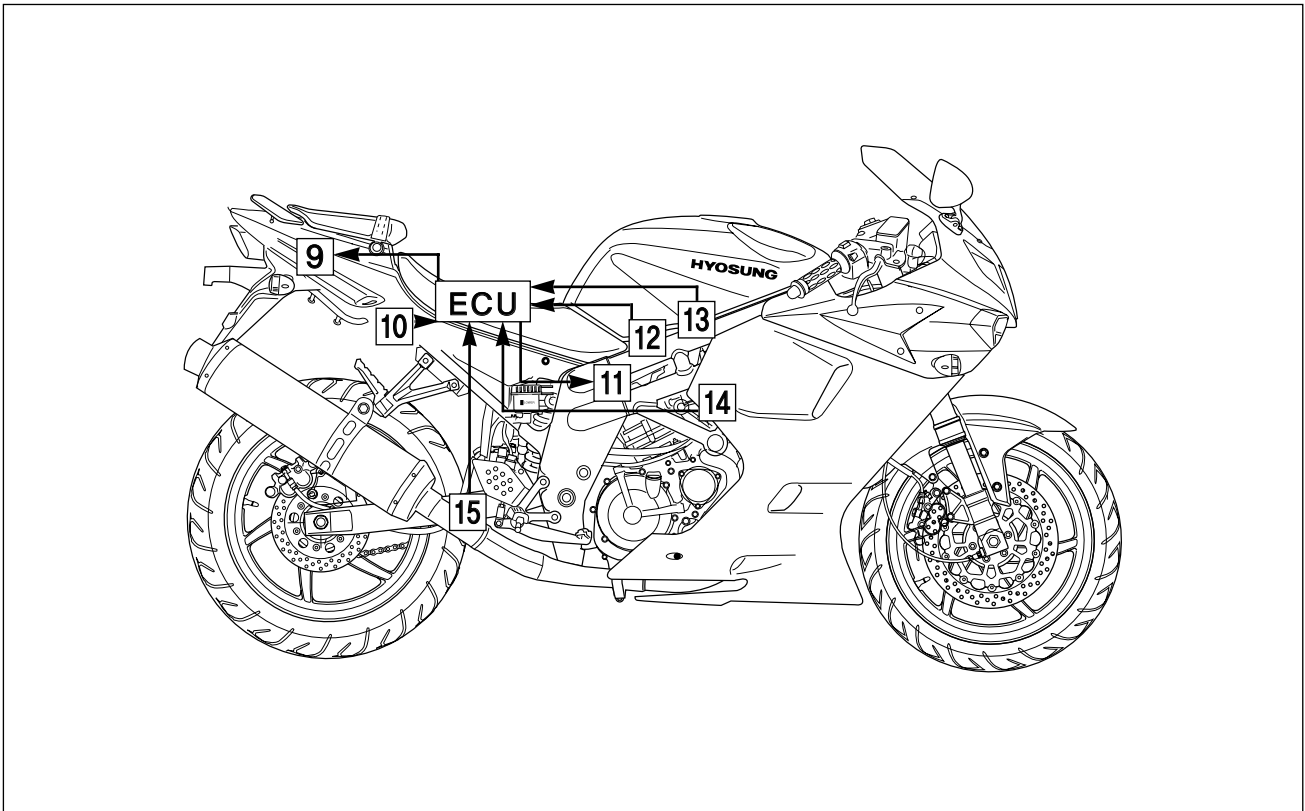

- | | |
|-----------------------|--------------------|
| ⑨ Fuel pump relay | ⑬ IAP sensor, NO.2 |
| ⑩ TO sensor | ⑭ WT sensor |
| ⑪ Ignition coil, NO.2 | ⑮ Oxygen sensor |
| ⑫ IAP sensor, NO.1 | |

SELF-DIAGNOSIS FUNCTION

The self-diagnosis function is incorporated in the ECU. The function has two modes, "USER MODE" and "DEALER MODE". The user can only be notified by the LCD(DISPLAY) panel ① and the "FI" check lamp "FI" ②. To check the function of the individual FI system devices, the dealer mode is prepared. In this check, the special tool is necessary to read the code of the malfunction items.

⊙ USER MODE

MALFUNCTION	LCD (DISPLAY) INDICATION ①	"FI" CHECK LAMP INDICATION ②	INDICATION MODE
"NO"	Speedometer	—	—
"YES" Engine can start Engine can not start	Speedometer and "FI" letters *1	"FI" check lamp comes on.	Each 2 sec. Speedometer or "FI" is indicated.
	"FI" letters *2	"FI" check lamp comes on and blinks.	"FI" is indicated continuously.

*1

When one of the signals is not received by ECU, the fail-safe circuit works and injection is not stopped. In this case, "FI" and speedometer are indicated in the LCD panel and motorcycle can run.

*2

The injection signal is stopped, when the crankshaft position sensor signal, tip over sensor signal, #1/#2 ignition signals, #1/#2 injector signals, fuel pump relay signal or ignition switch signal is not sent to ECU. In this case, "FI" is indicated in the LCD panel. Motorcycle does not run.

"CHEC" : The LCD panel indicates "CHE" when no communication signal from the ECU is received for 3 seconds.

For example, The ignition switch is turned "ON" position, and the engine stop switch is turned "OFF" position. In this case, the speedometer does not receive any signal from ECU, and the panel indicates "CHE".

If "CHE" is indicated, the LCD does not indicate the trouble code. It is necessary to check the wiring harness between ECU and speedometer couplers.

The possible cause of this indication is as follows, Engine stop switch is in "OFF" position. Ignition fuse is burnt.

Aquila 650 FI

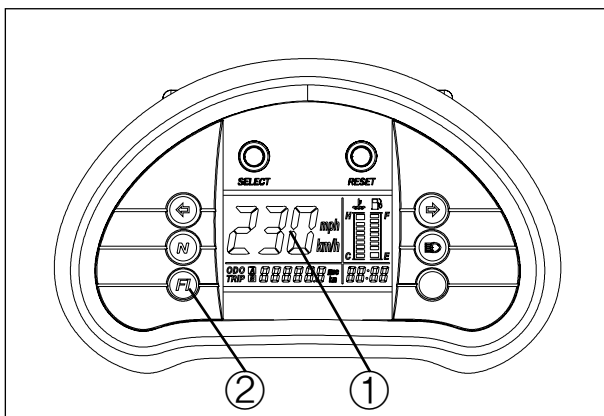

Comet 650/S/R FI

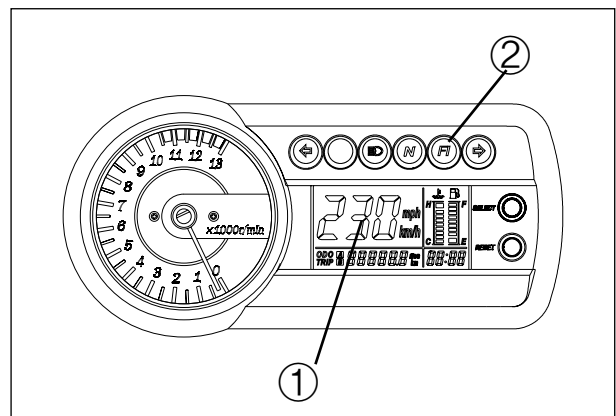

⦿ DEALER MODE

The defective function is memorized in the ECU. Use the special tool's coupler to connect to the dealer mode coupler. (Refer to page 4-1-16) The memorized malfunction code is displayed on LCD (DISPLAY) panel. Malfunction means that the ECU does not receive signal from the devices. These affected devices are indicated in the code form.

 **Mode select switch : 09900-27000**

Aquila 650 FI

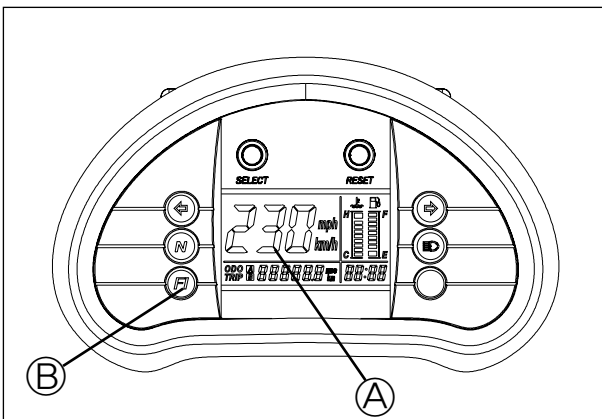

Comet 650 S/R FI

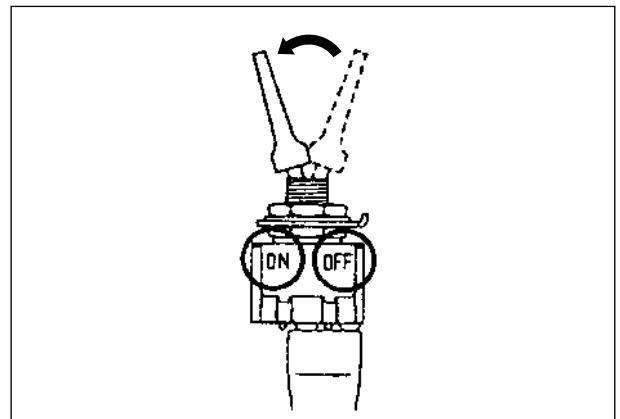
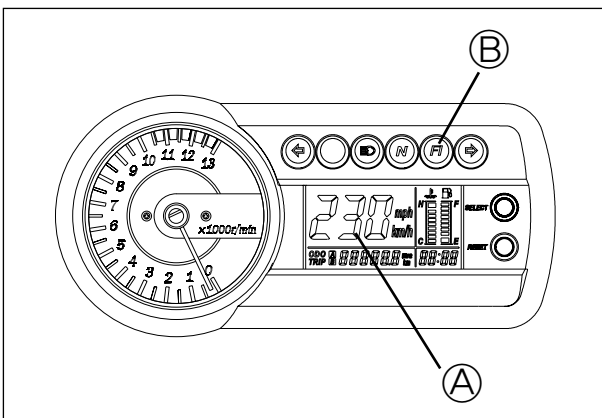

CAUTION

- ❖ Do not disconnect the ECU lead wire couplers, before checking the malfunction code, or the malfunction code memory is erased and the malfunction code can not be checked.
- ❖ Confirm the malfunction code after turn the ignition switch "ON" position or cranking the engine for few seconds.

MALFUNCTION	LCD (DISPLAY) INDICATION A	"FI" CHECK LAMP INDICATION B	INDICATION MODE
"NO"	C00		—
"YES"	C**code is indicated from small numeral to large one.	"FI" check lamp goes off.	For each 2 sec., code is indicated.

4-1-13 FI SYSTEM DIAGNOSIS

CODE	MALFUNCTION PART	REMARKS
C00	None	No defective part
C12	Pick-up coil	
C14	Throttle position sensor (TPS)	
C15	Water temperature sensor (WTS)	
C17	Intake air pressure sensor (IAPS), NO.1	For NO.1 cylinder
C18	Intake air pressure sensor (IAPS), NO.2	For NO.2 cylinder
C21	Intake air temperature sensor (IATS)	
C22	Oxygen sensor (O ₂ S)	
C23	Tip over sensor (TOS)	
C24	IG coil, NO.1	For NO.1 cylinder
C25	IG coil, NO.2	For NO.2 cylinder
C31	Gear position switch (GP switch)	
C32	Fuel injector, NO.1	For NO.1 cylinder
C33	Fuel injector, NO.2	For NO.2 cylinder
C41	Fuel pump relay	

In the LCD (DISPLAY) panel, the malfunction code is indicated from small code to large code.

FI SYSTEM TROUBLESHOOTING

CUSTOMER COMPLAINT ANALYSIS

Record details of the problem (failure, complaint) and how it occurred as described by the customer. For this purpose, use of such an inspection form will facilitate collecting information to the point required for proper analysis and diagnosis.

EXAMPLE : CUSTOMER PROBLEM INSPECTION FORM

User name :	Model :	VIN :	
Date of issue :	Date Reg.	Date of problem :	Mileage :

"FI" Check lamp	<input type="checkbox"/> Always ON <input type="checkbox"/> Sometimes ON <input type="checkbox"/> Always OFF <input type="checkbox"/> Good condition
Malfunction display / code (LCD)	<input type="checkbox"/> No code <input type="checkbox"/> Malfunction code ()

PROBLEM SYMPTOMS

<input type="checkbox"/> Difficult Starting <input type="checkbox"/> No cranking <input type="checkbox"/> No initial combustion <input type="checkbox"/> No combustion <input type="checkbox"/> Poor starting at (<input type="checkbox"/> cold <input type="checkbox"/> warm <input type="checkbox"/> always) <input type="checkbox"/> Other _____	<input type="checkbox"/> Poor Driveability <input type="checkbox"/> Hesitation on acceleration <input type="checkbox"/> Back fire / <input type="checkbox"/> After fire <input type="checkbox"/> Lack of power <input type="checkbox"/> Surging <input type="checkbox"/> Abnormal knocking <input type="checkbox"/> Engine rpm jumps briefly <input type="checkbox"/> Other _____
<input type="checkbox"/> Poor Idling <input type="checkbox"/> Poor fast idle <input type="checkbox"/> Abnormal idling speed (<input type="checkbox"/> High <input type="checkbox"/> Low) (rpm) <input type="checkbox"/> Unstable <input type="checkbox"/> Hunting (rpm. to rpm) <input type="checkbox"/> Other _____	<input type="checkbox"/> Engine Stall when <input type="checkbox"/> Immediately after start <input type="checkbox"/> Throttle valve is opened <input type="checkbox"/> Throttle valve is closed <input type="checkbox"/> Load is applied <input type="checkbox"/> Other _____
<input type="checkbox"/> OTHERS :	

4-1-15 FI SYSTEM DIAGNOSIS

MOTORCYCLE / ENVIRONMENTAL CONDITION WHEN PROBLEM OCCURS	
Environmental condition	
Weather	<input type="checkbox"/> Fair <input type="checkbox"/> Cloudy <input type="checkbox"/> Rain <input type="checkbox"/> Snow <input type="checkbox"/> Always <input type="checkbox"/> Other
Temperature	<input type="checkbox"/> Hot <input type="checkbox"/> Warm <input type="checkbox"/> Cool <input type="checkbox"/> Cold (°F / °C) <input type="checkbox"/> Always
Frequency	<input type="checkbox"/> Always <input type="checkbox"/> Sometimes (times / day, month) <input type="checkbox"/> Only once
	<input type="checkbox"/> Under certain condition
Road	<input type="checkbox"/> Urban <input type="checkbox"/> Suburb <input type="checkbox"/> Highway <input type="checkbox"/> Mountainous (<input type="checkbox"/> Uphill <input type="checkbox"/> Downhill)
	<input type="checkbox"/> Tarmacadam <input type="checkbox"/> Gravel <input type="checkbox"/> Other
Motorcycle condition	
Engine condition	<input type="checkbox"/> Cold <input type="checkbox"/> Warming up phase <input type="checkbox"/> Warmed up <input type="checkbox"/> Always <input type="checkbox"/> Other at starting
	<input type="checkbox"/> Immediately after start <input type="checkbox"/> Racing without load <input type="checkbox"/> Engine speed (rpm)
Motorcycle condition	During driving : <input type="checkbox"/> Constant speed <input type="checkbox"/> Accelerating <input type="checkbox"/> Decelerating
	<input type="checkbox"/> Right hand corner <input type="checkbox"/> Left hand corner <input type="checkbox"/> At stop
	<input type="checkbox"/> Motorcycle speed when problem occurs (km/h, Mile/h)
	<input type="checkbox"/> Other _____

NOTE
<i>The above form is a standard sample. It should be modified according to conditions characteristic of each market.</i>

SELF-DIAGNOSTIC PROCEDURES

Don't disconnect couplers from ECU, battery cable from battery, ECU ground wire harness from engine or main fuse before confirming malfunction code (self-diagnostic trouble code) stored in memory. Such disconnection will erase memorized information in ECU memory.

Malfunction code stored in ECU memory can be checked by the special tool.

To check malfunction code, read SELF-DIAGNOSIS FUNCTION "DEALER MODE" (Refer to page 4-1-12, 13) carefully to have good understanding as to what functions are available and how to use it.

Be sure to read "PRECAUTIONS for Electrical Circuit Service" (Refer to page 4-1-1) before inspection and observe what is written there.

- Remove the seat.
- Connect the special tool to the dealer mode coupler at the wiring harness, and the ignition switch is set to "ON" position.
- Turn the special tool's switch "ON" position and check the malfunction code to determine the malfunction part.

 **Mode select switch : 09900-27000**

NOTE

The dealer mode coupler is located under the seat.

SELF-DIAGNOSIS RESET PROCEDURE

- After repairing the trouble, turn the ignition switch "OFF" position and turn "ON" position again.
- If C00(LCD INDICATION ①) is indicates, the malfunction codes are cleared.
- Disconnect the special tool from the dealer mode coupler.

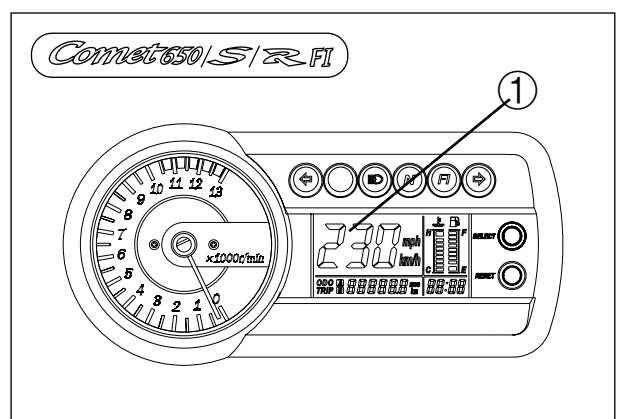
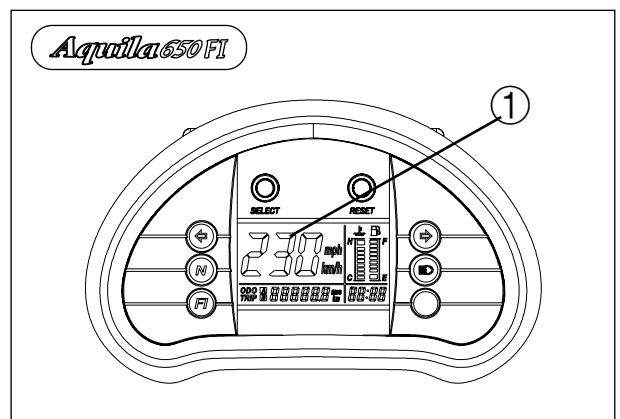
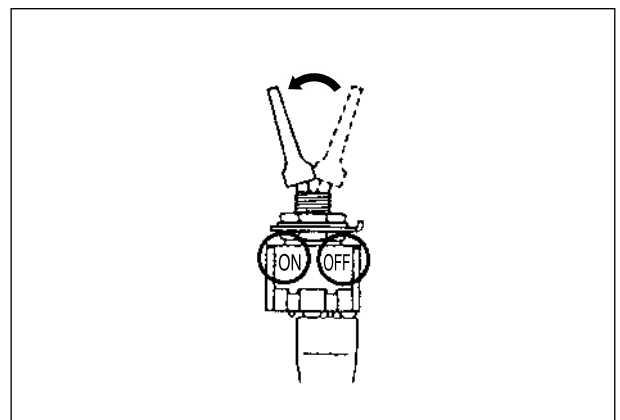

MALFUNCTION CODE AND DEFECTIVE CONDITION

MALFUNCTION CODE	DETECTED ITEM	DETECTED FAILURE CONDITION
		CHECK FOR
C00	NO FAULT	—
C12	Pick-up coil	The signal does not reach ECU for more than 2 sec. after receiving the IAP signal.
		Pick-up coil wiring and mechanical parts. (Pick-up coil, lead wire coupler connection)
C14	Throttle position sensor (TPS)	The sensor should produce following voltage. 0.2 V < sensor voltage < 4.8 V Without the above range for 5 sec. and more, C14 is indicated.
		Throttle position sensor, lead wire / coupler connection.
C15	Water temperature sensor (WTS)	The sensor voltage should be the following. 0.2 V < sensor voltage < 4.6 V Without the above range for 5 sec. and more, C15 is indicated.
		Water temperature sensor, lead wire / coupler connection.
C17 / C18	Intake air pressure sensor (IAPS), NO.1 / NO.2	The sensor should produce following voltage. 0.2 V < sensor voltage < 4.8 V Without the above range for 5 sec. and more, C17 or C18 is indicated.
		Intake air pressure sensor, lead wire / coupler connection.
C21	Intake air temperature sensor (IATS)	The sensor voltage should be the following. 0.2 V < sensor voltage < 4.6 V Without the above range for 5 sec. and more, C21 is indicated.
		Intake air temperature sensor, lead wire / coupler connection.
C22	Oxygen sensor (O ₂ S)	The oxygen sensor signal is input in ECU since then 180 sec. after the engine run. When this is the case, ECU not receive the signal, C22 is indicated.
		Oxygen sensor, lead wire / coupler connection.
C23	Tip over sensor (TOS)	The sensor voltage should be the following for more than 5 sec. after ignition switch turns "ON" position. 0.2 V < sensor voltage < 4.6 V Without the above value for 5 sec. and more, C23 is indicated.
		Tip over sensor, lead wire / coupler connection.

MALFUNCTION CODE	DETECTED ITEM	DETECTED FAILURE CONDITION
		CHECK FOR
C24 / C25	Ignition coil (IG coil), NO.1 / NO.2	Ignition signal is interrupted continuous by 32 times or more when ECU confirm ignition surge at each combustion chamber, C24 or C25 is indicated.
		Ignition coil, wiring / coupler connection, power supply from the battery.
C31	Gear position switch (GP switch)	It judges from gear position voltage, engine speed and throttle position by ECU, when the gear position voltage is 0.1 V and less.
		Gear position switch, wiring / coupler connection, gearshift cam etc.
C32 / C33	Fuel injector, NO.1 / NO.2	Injector signal is interrupted continuous by 16 times or more when ECU confirm injector running surge at each combustion chamber, C32 or C33 is indicated.
		Injector, wiring / coupler connection, power supply to the injector.
C41	Fuel pump relay	Voltage is applied continuous over 5 sec., battery voltage ≥ 5 V when fuel pump relay is "OFF" position or battery voltage < 5 V when fuel pump relay is "ON" position.
		Fuel pump relay, connecting lead wire, power source to fuel pump relay, fuel injector.

“C12” PICK-UP COIL CIRCUIT MALFUNCTION

DETECTED CONDITION	POSSIBLE CAUSE
The signal does not reach ECU for more than 2 sec. after receiving the IAP signal.	<ul style="list-style-type: none"> ● Metal particles or foreign material being attached on the pick-up coil and rotor tip. ● Pick-up coil circuit open or short. ● Pick-up coil malfunction. ● ECU malfunction.

▣ INSPECTION

◆ Step 1

- 1) Remove the frame cover.
- 2) Turn the ignition switch “OFF” position.
- 3) Check the pick-up coil coupler ① for loose or poor contacts. If OK, then measure the pick-up coil resistance.

- 4) Disconnect the pick-up coil coupler ① and measure the resistance.

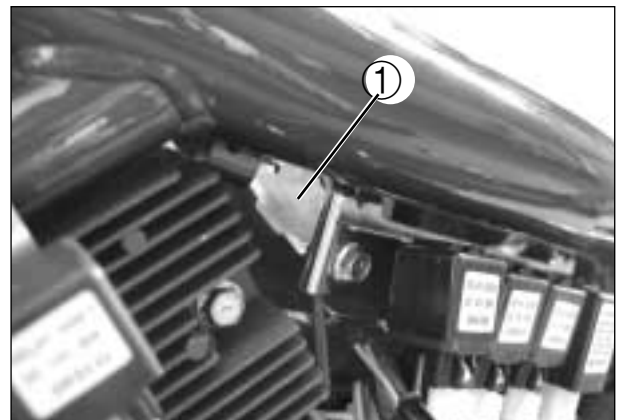

Pick-up coil resistance	110 ~ 140 Ω (G – L)
--------------------------------	------------------------

- 5) If OK, then check the continuity between each terminal and ground.

Pick-up coil continuity	∞ Ω (Infinity) (G – Ground) (L – Ground)
--------------------------------	--

 **Tester knob indication : Resistance (Ω)**

Are the resistance and continuity OK?

YES	<ul style="list-style-type: none"> ● L or G wire open or shorted to ground, or poor ③ or ⑮ connection. ● If wire and connection are OK, intermittent trouble or faulty ECU. ● Recheck each terminal and wire harness for open circuit and poor connection.
NO	<ul style="list-style-type: none"> ● Loose or poor contacts on the pick-up coil coupler or ECU coupler. ● Replace the pick-up coil with a new one.

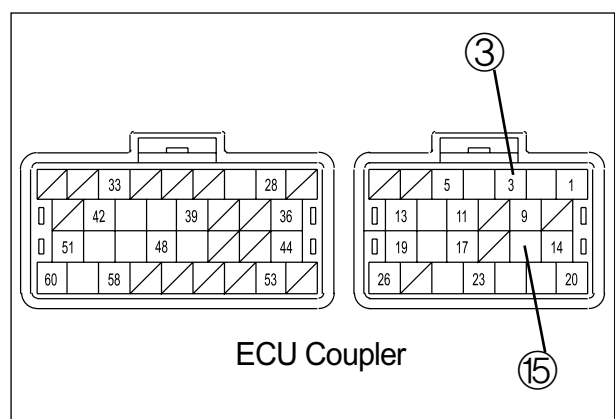

“C14” TP SENSOR CIRCUIT MALFUNCTION

DETECTED CONDITION	POSSIBLE CAUSE
Output voltage is out of the specified range. 0.2 V < Sensor voltage < 4.8 V	<ul style="list-style-type: none"> ● TP sensor circuit open or short. ● TP sensor malfunction. ● ECU malfunction.

▣ INSPECTION

◆ Step 1

- 1) Turn the ignition switch “OFF” position.
- 2) Check the TP sensor coupler for loose or poor contacts.
If OK, then measure the TP sensor input voltage.
- 3) Disconnect the TP sensor coupler.

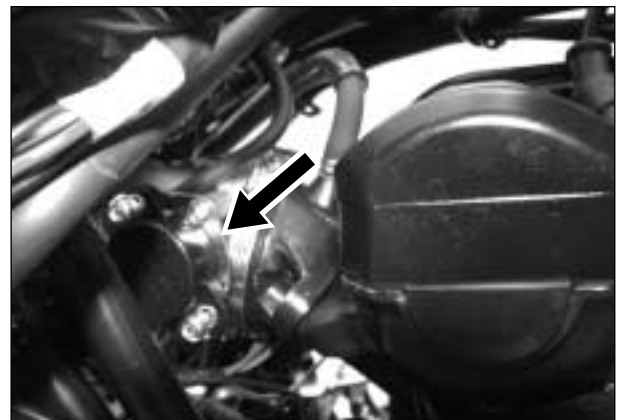

- 4) Turn the ignition switch “ON” position.
- 5) Measure the voltage at the OB wire and ground.
- 6) If OK, then measure the voltage at the OB wire and GR wire.

TP sensor input voltage	4.5 ~ 5.5 V (⊕ OB — ⊖ Ground) (⊕ OB — ⊖ GR)
--------------------------------	---

 **Tester knob indication : Voltage (---)**

Is the voltage OK?

YES	Go to Step 2.
NO	<ul style="list-style-type: none"> ● Loose or poor contacts on the ECU coupler. ● Open or short circuit in the OB wire or GR wire.

4-1-21 FI SYSTEM DIAGNOSIS

◆ Step 2

- 1) Remove the frame cover.
- 2) Turn the ignition switch "OFF" position.
- 3) Disconnect the TP sensor coupler.
- 4) Check the continuity between Ⓐ and ground.

TP sensor continuity	$\infty \Omega$ (Infinity) (Ⓐ - Ground)
-----------------------------	--

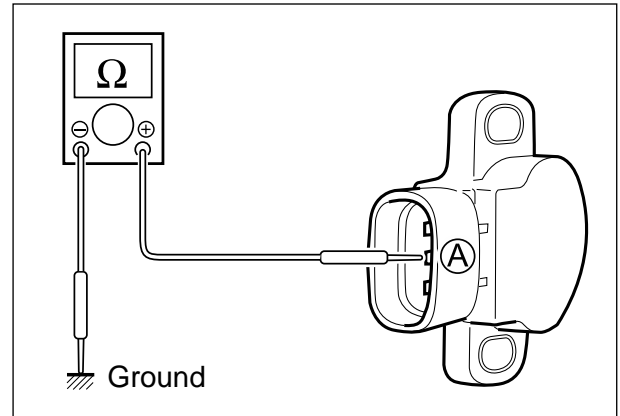

- 5) If OK, then measure the TP sensor resistance (between Ⓐ and Ⓑ).
- 6) Turn the throttle grip and measure the resistance.

TP sensor resistance	
Throttle valve is closed	Approx. 1.28 K Ω
Throttle valve is opened	Approx. 4.37 K Ω

 **Tester knob indication : Resistance (K Ω)**

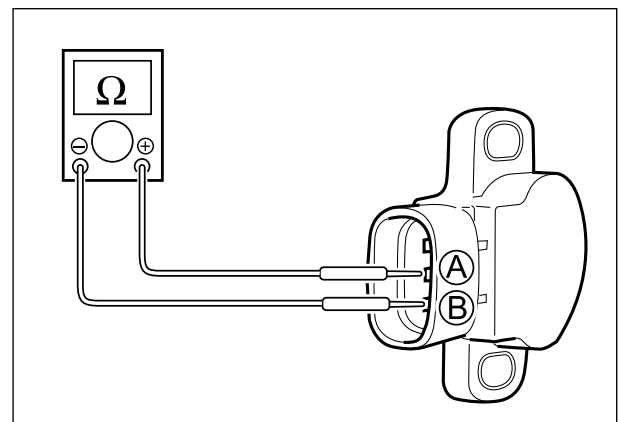

Are the resistance and continuity OK?

YES	Go to Step 3.
NO	<ul style="list-style-type: none"> ● Reset the TP sensor position correctly. ● Replace the TP sensor with a new one.

◆ Step 3

- 1) Connect the TP sensor coupler.
- 2) Insert the needle pointed probes to the lead wire coupler.
- 3) Turn the ignition switch "ON" position.
Measure the TP sensor output voltage at the coupler (between ⊕ LY and ⊖ GR) by turning the throttle grip.

TP sensor output voltage	
Throttle valve is closed	Approx. 1.12 V
Throttle valve is opened	Approx. 4.26 V

 Tester knob indication : Voltage (---)

Is the voltage OK?

YES	<ul style="list-style-type: none"> ● OB, LY or GR wire open or shorted to ground, or poor ②③, ⑤, or ⑤⑨ connection. ● If wire and connection are OK, intermittent trouble or faulty ECU. ● Recheck each terminal and wire harness for open circuit and poor connection.
NO	If check result is not satisfactory, replace TP sensor with a new one.

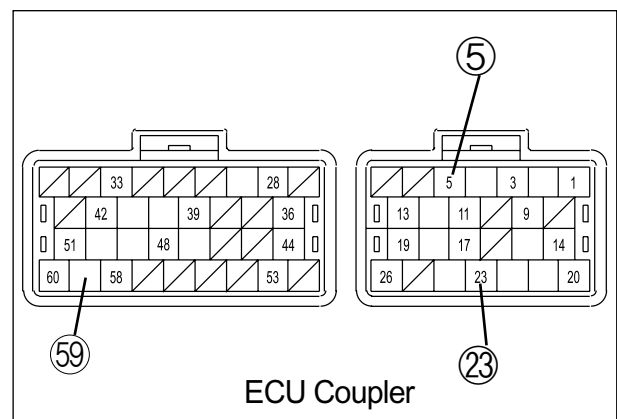
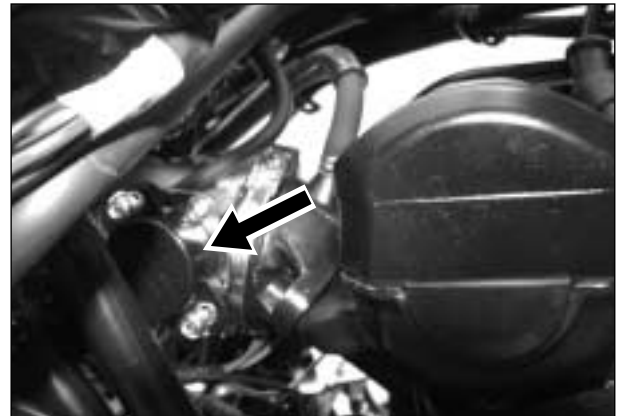

“C15” WT SENSOR CIRCUIT MALFUNCTION

DETECTED CONDITION	POSSIBLE CAUSE
Output voltage is out of the specified range. 0.2 V < Sensor voltage < 4.6 V	<ul style="list-style-type: none"> ● WT sensor circuit open or short. ● WT sensor malfunction. ● ECU malfunction.

▣ INSPECTION

◆ Step 1

- 1) Turn the ignition switch “OFF” position.
- 2) Check the WT sensor coupler for loose or poor contacts.
If OK, then measure the WT sensor voltage at the wire side coupler.
- 3) Disconnect the coupler and turn the ignition switch “ON” position.

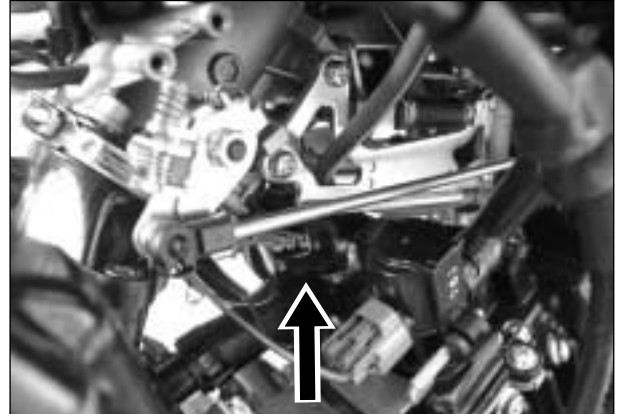

- 4) Measure the voltage between Br wire terminal and ground.
- 5) If OK, then measure the voltage between Br wire terminal and BW wire terminal.

WT sensor voltage	4.5 ~ 5.5 V (⊕ Br — ⊖ Ground) (⊕ Br — ⊖ BW)
--------------------------	---

 **Tester knob indication : Voltage (—)**

Is the voltage OK?

YES	Go to Step 2.
NO	<ul style="list-style-type: none"> ● Loose or poor contacts on the ECU coupler. ● Open or short circuit in the Br wire or BW wire.

◆ Step 2

- 1) Turn the ignition switch "OFF" position.
- 2) Measure the WT sensor resistance.

- ☞ Refer to the service manual 『*Aquilla650* (99000-51210)』 page 5-7
- ☞ Refer to the service manual 『*Comet650* (99000-94810)』 page 5-7

WT sensor resistance	
Engine Coolant Temp.	Resistance (To ECU)
0 °C (32 °F)	Approx. 5.790 KΩ
20 °C (68 °F)	Approx. 2.450 KΩ
40 °C (104 °F)	Approx. 1.148 KΩ
60 °C (140 °F)	Approx. 0.586 KΩ
80 °C (176 °F)	Approx. 0.322 KΩ

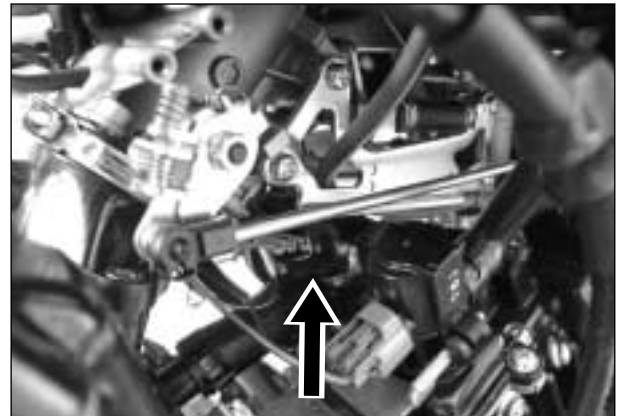

🔧 Tester knob indication : Resistance (KΩ)

Is the resistance OK?

YES	<ul style="list-style-type: none"> ● Br or BW wire open or shorted to ground, or poor ⑬ or ⑤⑨ connection. ● If wire and connection are OK, intermittent trouble or faulty ECU. ● Recheck each terminal and wire harness for open circuit and poor connection.
NO	Replace the WT sensor with a new one.

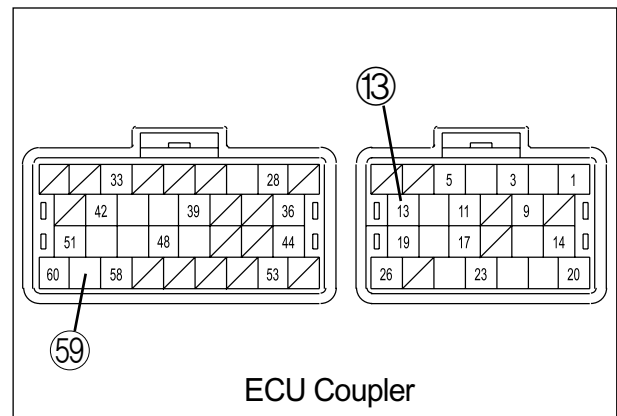

“C17” or “C18” IAP SENSOR CIRCUIT MALFUNCTION

DETECTED CONDITION	POSSIBLE CAUSE
<p>IAP sensor voltage is out of the specified range. $0.2\text{ V} < \text{Sensor voltage} < 4.8\text{ V}$ NOTE : <i>Note that atmospheric pressure varies depending on weather conditions as well as altitude. Take that into consideration when inspecting voltage.</i></p>	<ul style="list-style-type: none"> ● Clogged vacuum passage between throttle body and IAP sensor. ● Air being drawn from vacuum passage between throttle body and IAP sensor. ● IAP sensor circuit open or shorted to ground. ● IAP sensor malfunction. ● ECU malfunction.

▣ INSPECTION

◆ Step 1

- 1) Remove the fuel tank.
- 2) Turn the ignition switch “OFF” position.
- 3) Check the IAP sensor NO.1 coupler ① and NO.2 coupler ② for loose or poor contacts. If OK, then measure the IAP sensor input voltage.

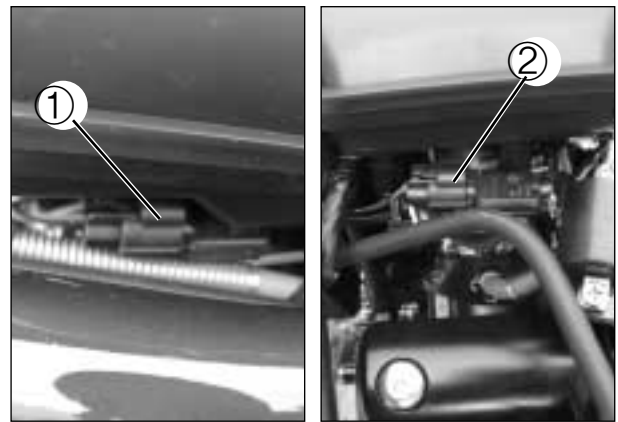

- 4) Disconnect the IAP sensor coupler NO.1 ③ and NO.2 ④.
- 5) Turn the ignition switch “ON” position.
- 6) Measure the voltage at the OB wire and ground. If OK, then measure the voltage at the OB wire and GR wire.

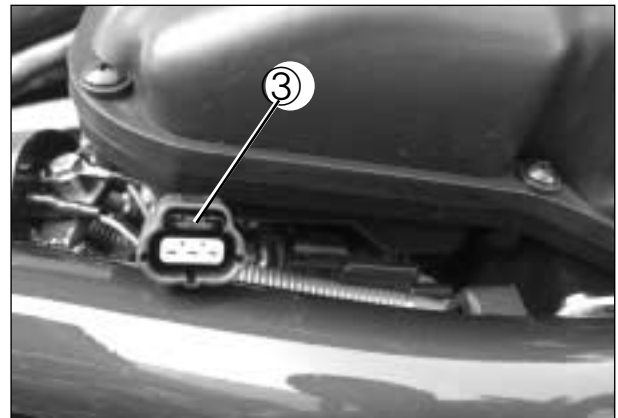

IAP sensor input voltage	4.5 ~ 5.5 V (⊕ OB — ⊖ Ground) (⊕ OB — ⊖ GR)
---------------------------------	---

Tester knob indication : Voltage (---)

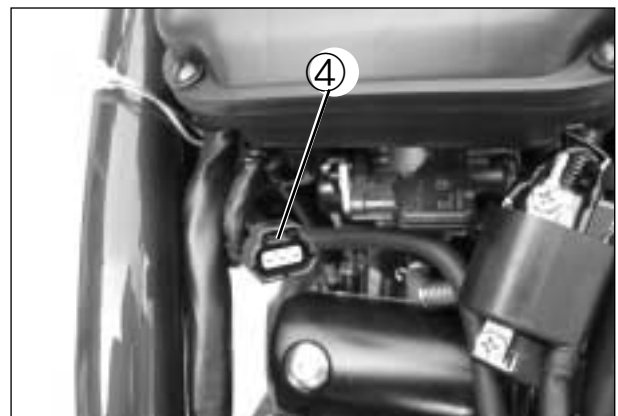

Is the voltage OK?

YES	Go to Step 2.
NO	<ul style="list-style-type: none"> ● Loose or poor contacts on the ECU coupler. ● Open or short circuit in the OB wire or GR wire.

◆ Step 2

- 1) Connect the IAP sensor coupler NO.1 ① and NO.2 ②.
- 2) Insert the needle pointed probes to the lead wire coupler.
- 3) Start the engine at idle speed.
- 4) Measure the IAP sensor output voltage at the wire side coupler (between BL and GR wires).

IAP sensor output voltage	Approx. 2.7 V at idle speed (⊕ BL ⊖ GR)
----------------------------------	---

 **Tester knob indication : Voltage (---)**

Is the voltage OK?

YES	<ul style="list-style-type: none"> ● OB, BL(NO.1), BY(NO.2) or GR wire open or shorted to ground, or poor ⑳, ⑰ (NO.1), ⑱ (NO.2) or ⑤⑨ connection. ● If wire and connection are OK, intermittent trouble or faulty ECU. ● Recheck each terminal and wire harness for open circuit and poor connection.
NO	If check result is not satisfactory, replace IAP sensor with a new one.

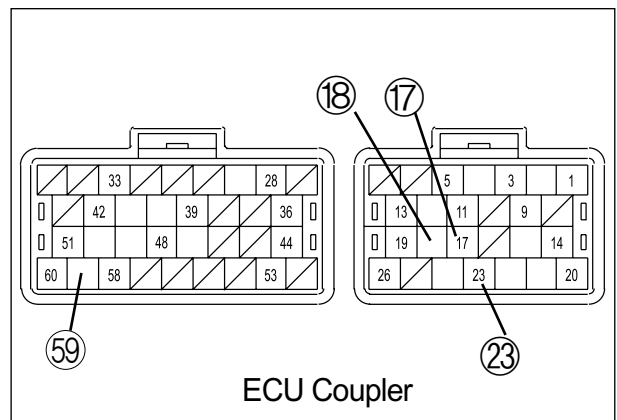
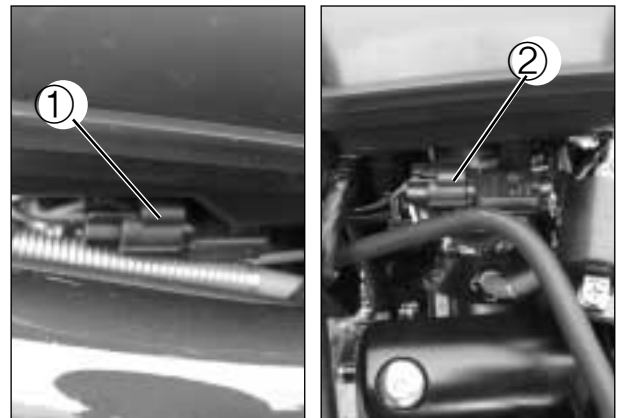

Output voltage (Input voltage 5 V, ambient temp. 25 °C, 77 °F)				
ALTITUDE (Reference)		ATMOSPHERIC PRESSURE		OUTPUT VOLTAGE
(ft)	(m)	(mmHg)	kPa	(V)
0	0	760	100	Approx. 3.7 ~ 3.9
2 000	610	707	94	Approx. 3.3 ~ 3.7
2 001	611	707	94	Approx. 3.0 ~ 3.3
5 000	1 524	634	85	Approx. 2.7 ~ 3.0
5 001	1 525	634	85	Approx. 2.7 ~ 3.0
8 000	2 438	567	76	Approx. 2.7 ~ 3.0
8 001	2 439	567	76	Approx. 2.7 ~ 3.0
10 000	3 048	526	70	

“C21” IAT SENSOR CIRCUIT MALFUNCTION

DETECTED CONDITION	POSSIBLE CAUSE
Output voltage is out of the specified range. 0.2 V < Sensor voltage < 4.6 V	<ul style="list-style-type: none"> ● IAT sensor circuit open or short. ● IAT sensor malfunction. ● ECU malfunction.

▣ INSPECTION

◆ Step 1

- 1) Remove the fuel tank.
- 2) Turn the ignition switch “OFF” position.
- 3) Check the IAT sensor coupler for loose or poor contacts.
If OK, then measure the IAT sensor voltage at the wire side coupler.
- 4) Disconnect the coupler and turn the ignition switch “ON” position.

- 5) Measure the voltage between GW wire terminal and ground.
- 6) If OK, then measure the voltage between GW wire terminal and GR wire terminal.

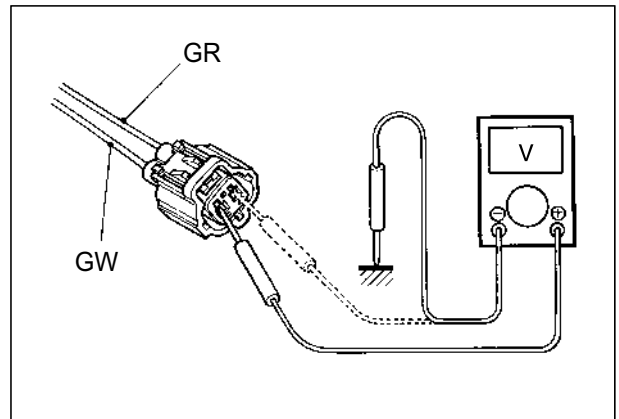

IAT sensor voltage	4.5 ~ 5.5 V (⊕ GW — ⊖ Ground) (⊕ GW — ⊖ GR)
---------------------------	---

Tester knob indication : Voltage (---)

Is the voltage OK?

YES	Go to Step 2.
NO	<ul style="list-style-type: none"> ● Loose or poor contacts on the ECU coupler. ● Open or short circuit in the GW wire or GR wire.



◆ Step 2

- 1) Turn the ignition switch "OFF" position.
- 2) Measure the IAT sensor resistance.

IAT sensor resistance	
Intake Air Temp.	Resistance
0 °C (32 °F)	Approx. 5.4 ~ 6.6 KΩ
80 °C (176 °F)	Approx. 0.29 ~ 0.39 KΩ

 **Tester knob indication : Resistance (KΩ)**

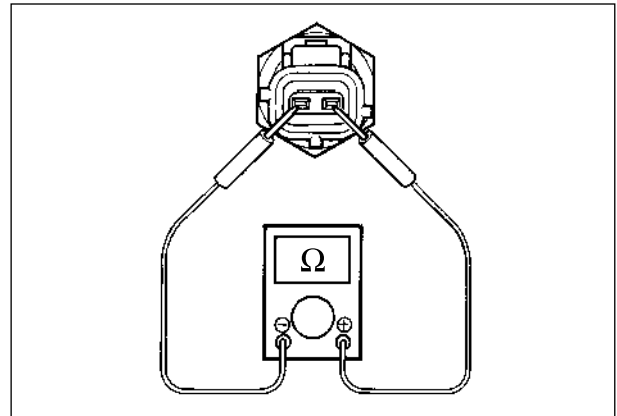

Is the resistance OK?

YES	<ul style="list-style-type: none"> ● GW or GR wire open or shorted to ground, or poor⑪ or ⑤⑨ connection. ● If wire and connection are OK, intermittent trouble or faulty ECU. ● Recheck each terminal and wire harness for open circuit and poor connection.
NO	Replace the IAT sensor with a new one.

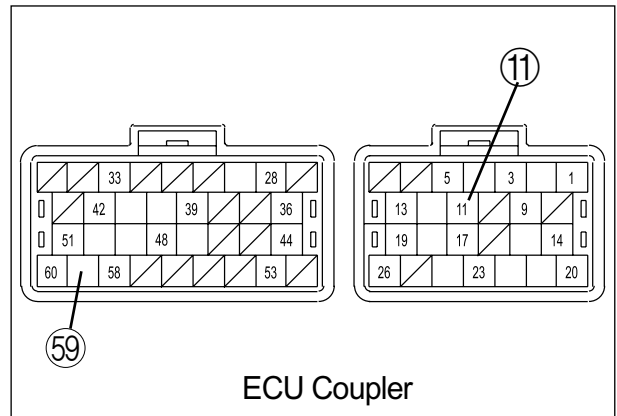

NOTE

IAT sensor resistance measurement method is the same way as that of the WT sensor.

☞ Refer to the service manual "Aquila 650 (99000-51210)", page 5-7

☞ Refer to the service manual "Comet 650 (99000-94810)", page 5-7

“C22” OXYGEN SENSOR CIRCUIT MALFUNCTION

DETECTED CONDITION	POSSIBLE CAUSE
Oxygen sensor signal is not input in ECU since then more than 180 sec. after the engine run.	<ul style="list-style-type: none"> ● Oxygen sensor, Oxygen sensor heater circuit open or short. ● Oxygen sensor, Oxygen sensor heater malfunction. ● ECU malfunction.

▣ INSPECTION

- 1) Remove the seat.
- 2) Turn the ignition switch “OFF” position.
- 3) Check the Oxygen sensor coupler for loose or poor contacts.



Is OK?

YES	<ul style="list-style-type: none"> ● B or GR wire open or shorted to ground, or poor ⑨ or ⑤⑨ connection. (Sensor) ● OB or B wire open or shorted to ground, or poor ②④ or ④④ connention. (Heater) ● If wire and connection are OK, intermittent trouble or faulty ECU. ● Recheck each terminal and wire harness for open circuit and poor connection.
NO	Replace the Oxygen sensor.

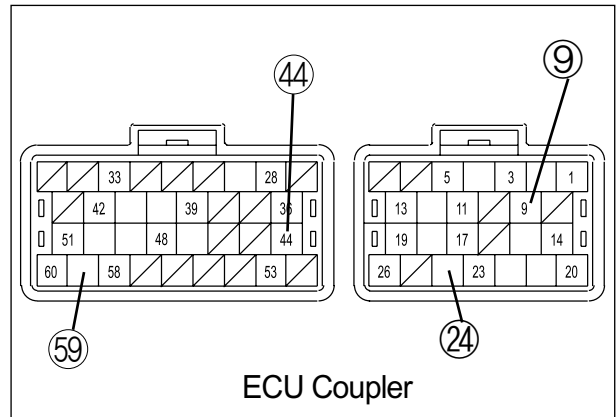

“C23” TO SENSOR CIRCUIT MALFUNCTION

DETECTED CONDITION	POSSIBLE CAUSE
Output voltage is out of the specified range. 0.2 V < Sensor voltage < 4.6 V	<ul style="list-style-type: none"> ● TO sensor circuit short or leaned more than 60°. ● TO sensor malfunction. ● ECU malfunction.

INSPECTION

◆ Step 1

- 1) Remove the seat.
- 2) Turn the ignition switch “OFF” position.
- 3) Check the TO sensor coupler for loose or poor contacts.
If OK, then measure the TO sensor resistance.
- 4) Remove the TO sensor.
- 5) Measure the resistance between B wire and GR wire terminals.

TO sensor resistance

19.1 ~ 19.7 kΩ
(B – GR)

Tester knob indication : Resistance (kΩ)

Is the resistance OK?

YES	Go to step 2
NO	Replace the TO sensor with a new one.



4-1-31 FI SYSTEM DIAGNOSIS

◆ Step 2

- 1) Connect the TO sensor coupler.
- 2) Insert the needle pointed probe to the lead wire coupler.
- 3) Turn the ignition switch "ON" position.
- 4) Measure the voltage at the wire side coupler between OB and GR wires of the TO sensor at horizontal.



TO sensor voltage

0.4 ~ 1.4 V
at normal condition
(⊕ OB — ⊖ GR)

Also, measure the voltage when leaning of the motorcycle.

- 5) Measure the voltage when it is leaned more than 65°, left and right, from the horizontal level.

TO sensor voltage

3.7 ~ 4.4 V
at leaned more than 65°
(⊕ OB — ⊖ GR)

 Tester knob indication : Voltage (---)

Is the voltage OK?

YES	<ul style="list-style-type: none"> ● OB, B or GR wire open or shorted to ground, or poor ②, ④ or ⑤ connection. ● If wire and connection are OK, intermittent trouble or faulty ECU. ● Recheck each terminal and wire harness for open circuit and poor connection.
NO	<ul style="list-style-type: none"> ● Loose or poor contacts on the ECU coupler. ● Open or short circuit in the OB wire or GR wire. ● Replace the TO sensor with a new one.

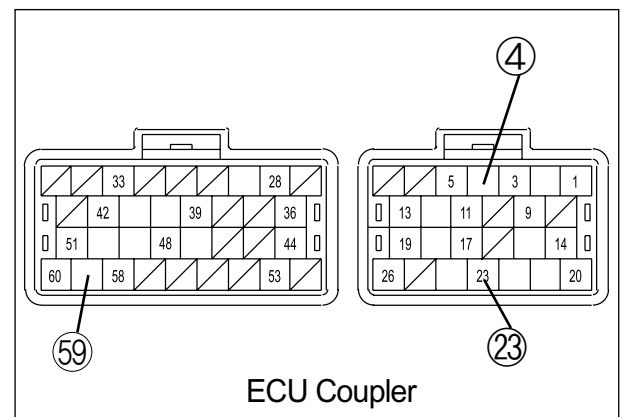

“C24” or “C25” IGNITION COIL MALFUNCTION

☞ Refer to the IGNITION COIL for details.

[Refer to the service manual 『*Aquila 650* (99000-51210)』 page 6-5,

Refer to the service manual 『*Comet 650* (99000-94810)』 page 6-5]

“C31” GP SWITCH CIRCUIT MALFUNCTION

DETECTED CONDITION	POSSIBLE CAUSE
No Gear Position switch voltage Switch voltage is out of the specified range. Switch Voltage ≤ 0.1 V	<ul style="list-style-type: none"> ● GP switch circuit open or short. ● GP switch malfunction. ● ECU malfunction.

INSPECTION

◆ Step 1

- 1) Remove the frame cover.
- 2) Turn the ignition switch “OFF” position.
- 3) Check the GP switch coupler for loose or poor contacts.
If OK, then measure the GP switch resistance.

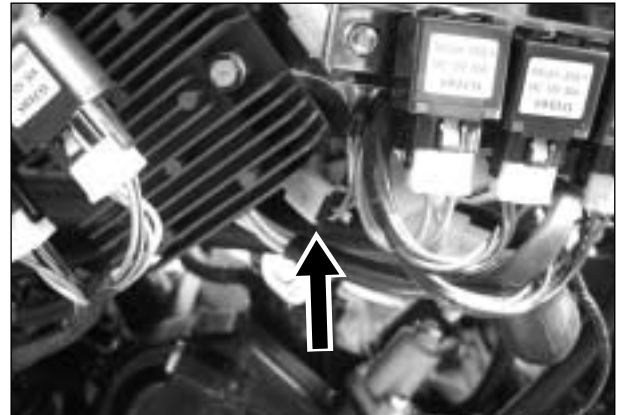

- 4) Support the motorcycle with a jack.
- 5) Turn the side-stand to up-right position.
- 6) Make sure the engine stop switch is in the “○” position.
- 7) Insert the needle pointed probes to the GP switch coupler.
- 8) Turn the ignition switch “ON” position.
- 9) Measure the resistance at the wire side coupler between GL wire and BW wire, when shifting the gearshift lever from 1st to Top.

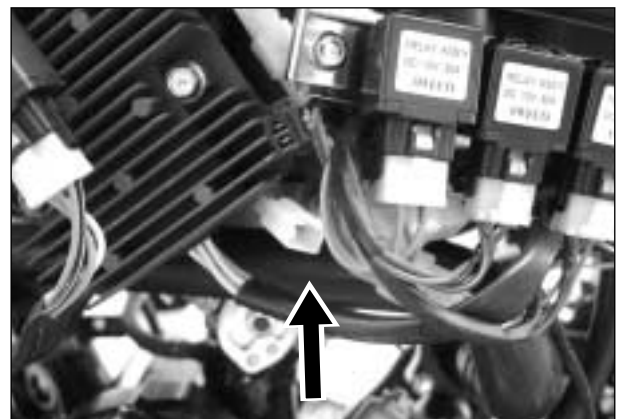

GP switch resistance	100 Ω ~ 2.0 K Ω (GL – BW)
-----------------------------	--

Tester knob indication : Resistance (K Ω)

Is the resistance OK?

YES	<ul style="list-style-type: none"> ● GL wire open or shorted to ground, or poor⑫ connection. ● If wire and connection are OK, intermittent trouble or faulty ECU. ● Recheck each terminal and wire harness for open circuit and poor connection.
NO	Open or short circuit in the GL wire.

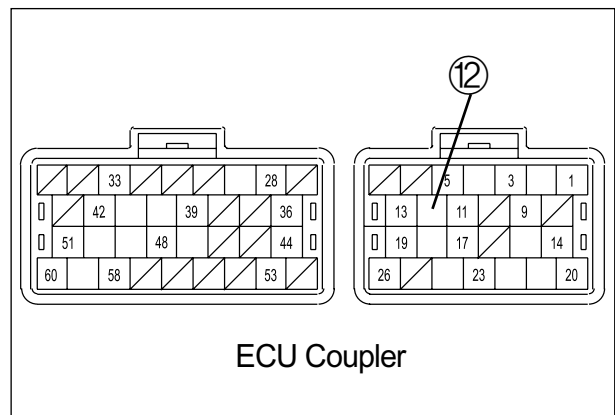

“C32” or “C33” FUEL INJECTOR CIRCUIT MALFUNCTION

DETECTED CONDITION	POSSIBLE CAUSE
Injector signal is interrupted continuous by 16 times or more when ECU confirm injector running surge at each combustion chamber.	<ul style="list-style-type: none"> ● Injector circuit open or short. ● Injector malfunction. ● ECU malfunction.

▣ INSPECTION

◆ Step 1

- 1) Remove the fuel tank and frame cover.
- 2) Turn the ignition switch “OFF” position.
- 3) Check the injector couplers NO.1 ① and NO.2 ② for loose or poor contacts.
If OK, then measure the injector resistance.

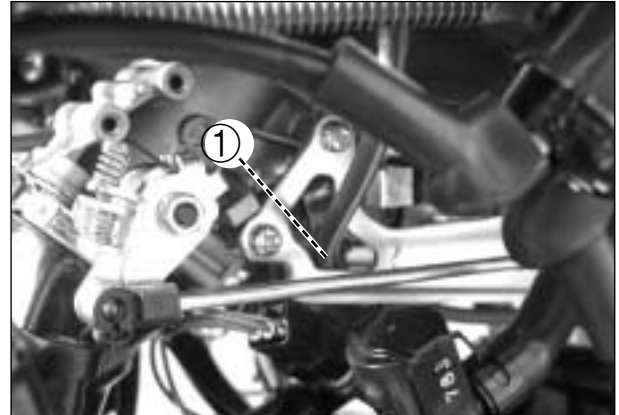

- 4) Disconnect the injector couplers NO.1 ① and NO.2 ② and measure the resistance between terminals.

Injector resistance	11.0 ~ 13.0 Ω at 20°C (68°F) (① – ②)
----------------------------	---



- 5) If OK, then check the continuity between injector terminals and ground.

Injector continuity	∞ Ω (Infinity) (① – Ground)
----------------------------	--------------------------------

 **Tester knob indication : Resistance (Ω)**

Are the resistance and continuity OK?

YES	Go to Step 2
NO	Replace the Injector with a new one.

◆ Step 2

- 1) Turn the ignition switch "ON" position.
- 2) Measure the injector voltage between YR(NO.1), RB(NO.2) wire and ground.

Injector voltage	Battery voltage
	(⊕ YR[NO.1] - ⊖ Ground) (⊕ RB[NO.2] - ⊖ Ground)

 **Tester knob indication : Voltage (---)**

NOTE

Injector voltage can be detected only 3 seconds after ignition switch is turned "ON" position.

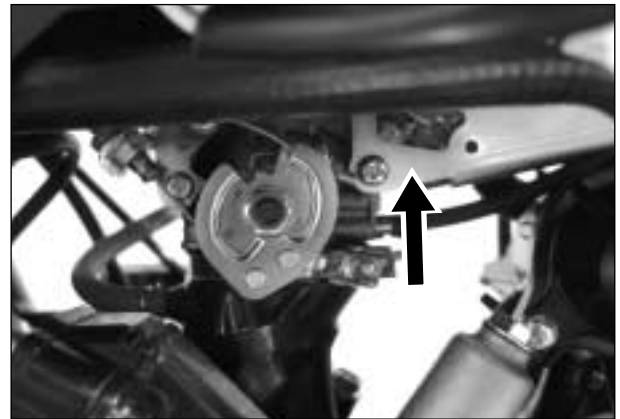
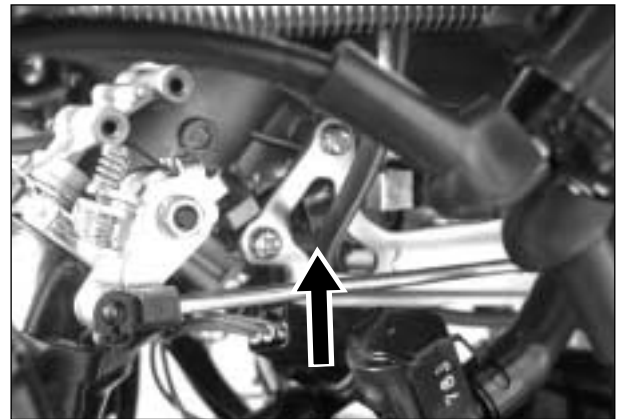

Is the voltage OK?

YES	<ul style="list-style-type: none"> ● YR(NO.1), RB(NO.2) wire open or shorted to ground, or poor 29 (NO.1), 36(NO.2) connection. ● If wire and connection are OK, intermittent trouble or faulty ECU. ● Recheck each terminal and wire harness for open circuit and poor connection.
NO	<ul style="list-style-type: none"> ● Inspect the fuel pump or fuel pump relay. (Refer to page 4-2-5)

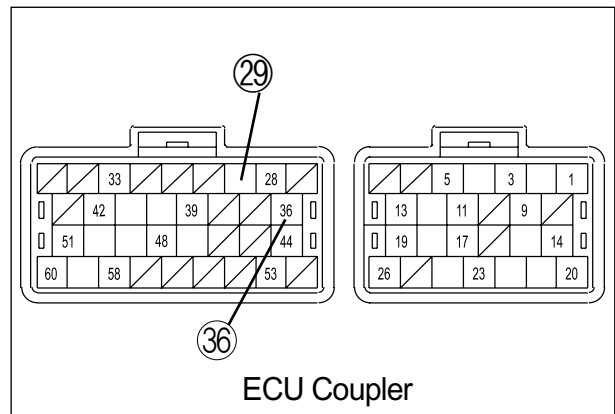

“C41” FUEL PUMP RELAY CIRCUIT MALFUNCTION

DETECTED CONDITION	POSSIBLE CAUSE
Voltage is applied continuous over 5 sec., battery voltage ≥ 5 V when fuel pump relay is “OFF” position or battery voltage < 5 V when fuel pump relay is “ON” position.	<ul style="list-style-type: none"> ● Fuel pump relay circuit open or short. ● Fuel pump relay malfunction. ● ECU malfunction.

▣ INSPECTION

◆ Step 1

- 1) Remove the frame cover.
- 2) Turn the ignition switch “OFF” position.
- 3) Check the fuel pump relay coupler for loose or poor contacts.
If OK, then check the insulation and continuity. Refer to page 4-2-5 for details.

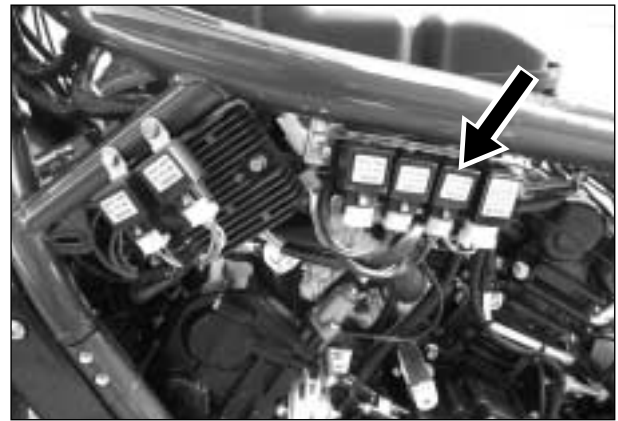

Is the Fuel pump relay OK?

YES	<ul style="list-style-type: none"> ● GW wire open or shorted to ground, or poor ⑤⑧ connection. ● If wire and connection are OK, intermittent trouble or faulty ECU. ● Recheck each terminal and wire harness for open circuit and poor connection. ● Inspect the fuel injectors. (Refer to page 4-1-33)
NO	Replace the fuel pump relay with a new one.

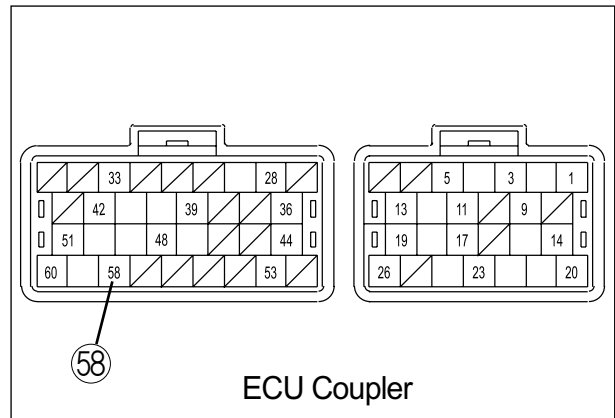

SENSORS

⊙ PICK-UP COIL INSPECTION

The pick-up coil① is installed in the magneto cover.

⊙ PICK-UP COIL REMOVAL AND INSTALLATION

- Remove the magneto cover.
- Install the magneto cover in the reverse order of removal.

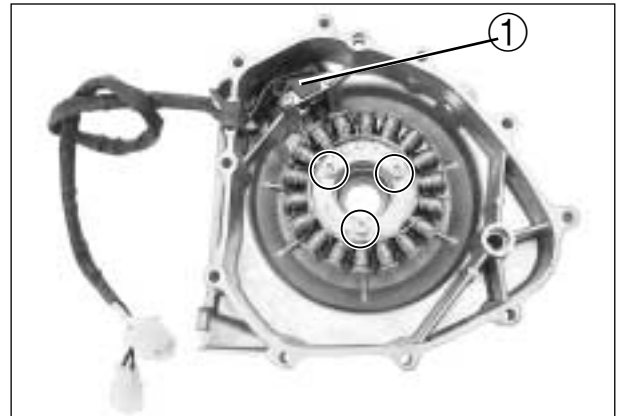

⊙ IAP SENSOR INSPECTION

The intake air pressure (IAP) sensor NO.1 ② and NO.2 ③ is installed at the side of the air cleaner. (Refer to page 4-1-25)

⊙ IAP SENSOR REMOVAL AND INSTALLATION

- Remove the fuel tank.
- Remove the IAP sensor from the downside of air cleaner.
- Install the IAP sensor in the reverse order of removal.

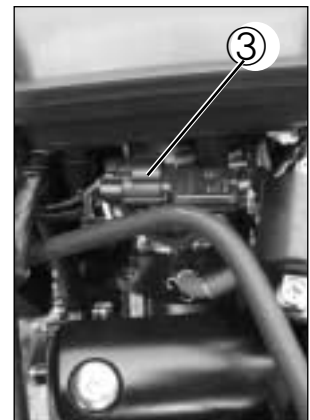
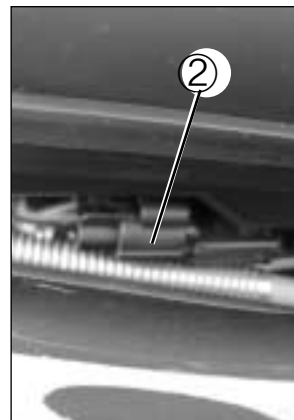

⊙ TP SENSOR INSPECTION

The throttle position (TP) sensor④ is installed at the left side of the throttle body. (Refer to page 4-1-20)

⊙ TP SENSOR REMOVAL AND INSTALLATION

 CAUTION
Never remove the TP sensor.

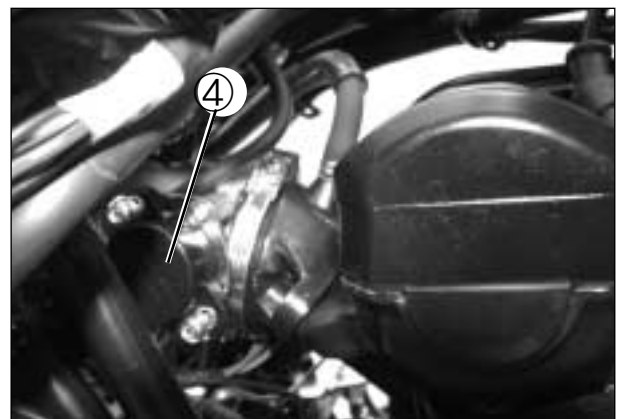

⊙ WT SENSOR INSPECTION

The water temperature (WT) sensor⑤ is installed at the rear side of the thermostat case. (Refer to page 4-1-23)

⊙ WT SENSOR REMOVAL AND INSTALLATION

- Remove the WT sensor.
- Install the WT sensor in the reverse order of removal.

 WT sensor : 18 N · m (1.8 kgf · m)

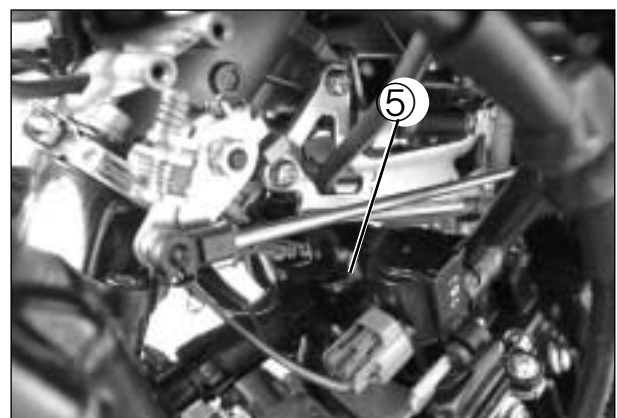

⊙ IAT SENSOR INSPECTION

The intake air temperature (IAT) sensor ① is installed at the downside of the air cleaner case. (Refer to page 4-1-27)

⊙ IAT SENSOR REMOVAL AND INSTALLATION

- Remove the fuel tank.
- Remove the IAT sensor from the air cleaner case.
- Install the IAT sensor in the reverse order of removal.



⊙ TO SENSOR INSPECTION, REMOVAL AND INSTALLATION

The tip over (TO) sensor ② is located in the upside of the battery. (Refer to page 4-1-30)

- Remove the fuel tank.
- Remove the TO sensor from the frame.
- Install the TO sensor in the reverse order of removal.



FUEL SYSTEM AND THROTTLE BODY

CONTENTS

FUEL SYSTEM	50 (4-2-1)
REMOVAL AND DISASSEMBLY	52 (4-2-3)
REASSEMBLY AND INSTALLATION	53 (4-2-4)
FUEL PRESSURE INSPECTION	54 (4-2-5)
FUEL PUMP RELAY INSPECTION	54 (4-2-5)
FUEL MESH FILTER INSPECTION AND CLEANING	55 (4-2-6)
FUEL LEVEL GAUGE INSPECTION	55 (4-2-6)
THROTTLE BODY	56 (4-2-7)
REMOVAL	57 (4-2-8)
CLEANING	58 (4-2-9)
INSPECTION	58 (4-2-9)
INSTALLATION	58 (4-2-9)

4-2

FUEL SYSTEM

Aquila 650 FI

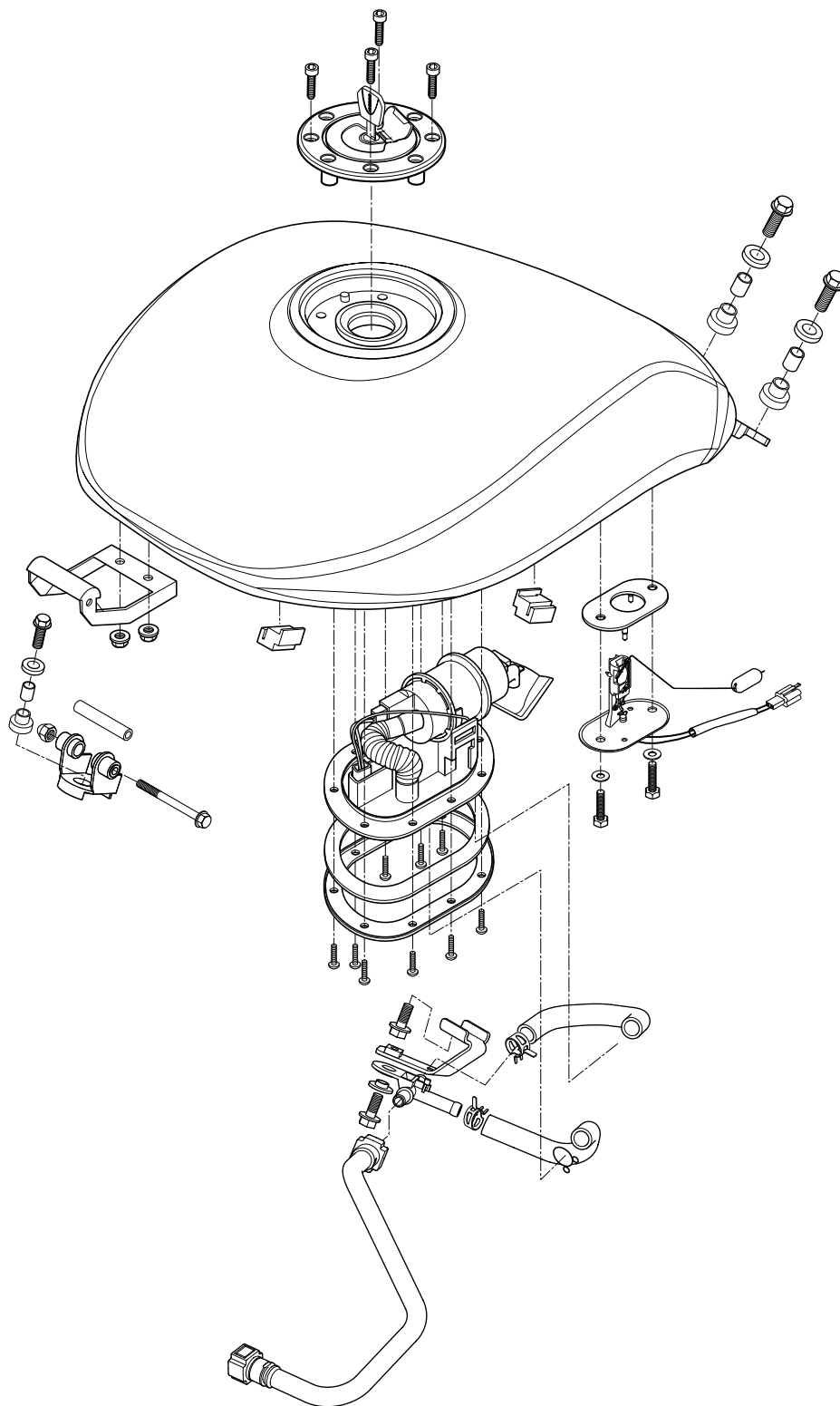

Comet 650/S/R FI

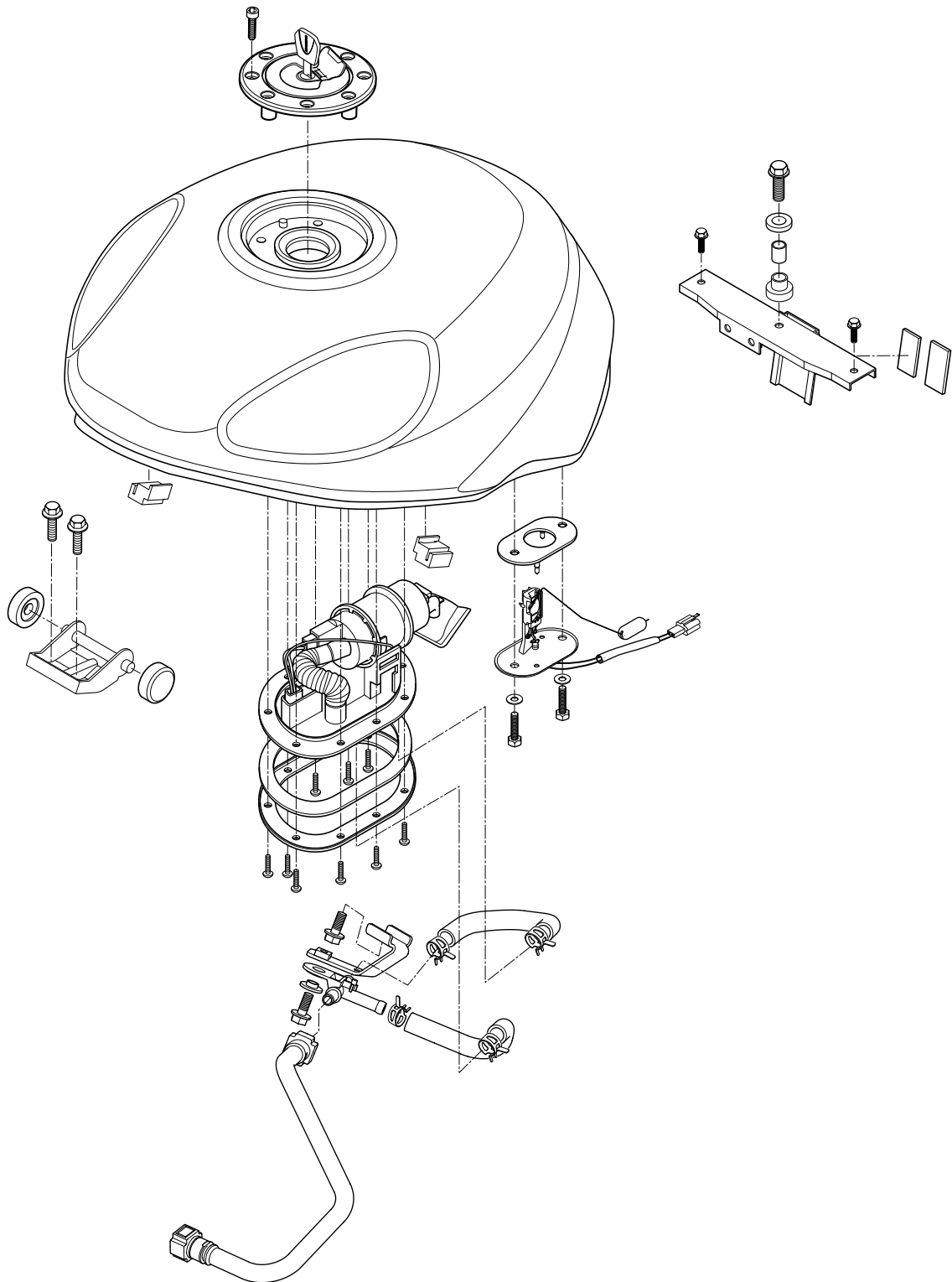

REMOVAL AND DISASSEMBLY

- Remove the seat. (*Aquila650FI*)
 - Remove the front seat. (*Comet650/S/RFI*)
-
- Remove the fuel tank mounting bolts and fuel tank bracket mounting bolt. (*Aquila650FI*)
 - Remove the fuel tank mounting bolts and take off the hooks. (*Comet650/S/RFI*)



- Disconnect the fuel level gauge coupler①.

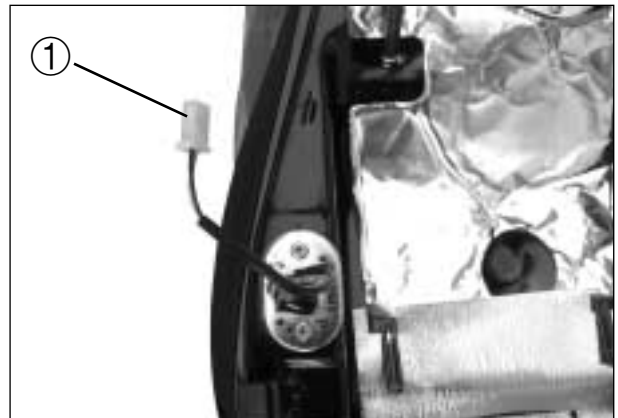

- Remove the fuel pump coupler②.
- Remove the fuel injector hose③ and return hose④.

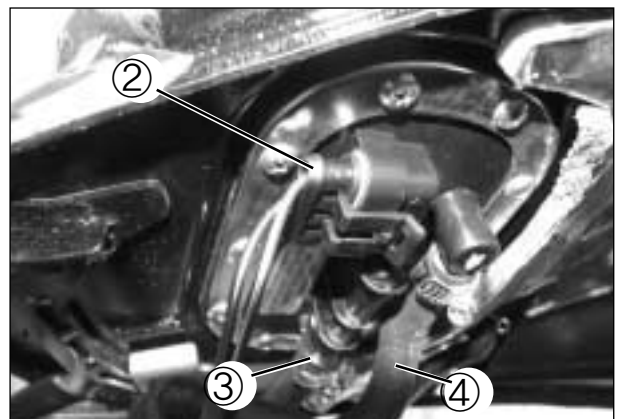

⚠ CAUTION

After disconnecting the fuel injector hose③, insert a blind plug into the end to stop fuel leakage.

- Remove the fuel tank rearward.

⚠ CAUTION

As gasoline leakage may occur in this operation, keep away from fire and sparks.

- Remove the fuel pump assembly ① by removing its mounting bolts diagonally.

⚠ WARNING

- ❖ Gasoline is highly flammable and explosive.
- ❖ Keep heat, spark and flame away.

- Remove the fuel gauge ② .

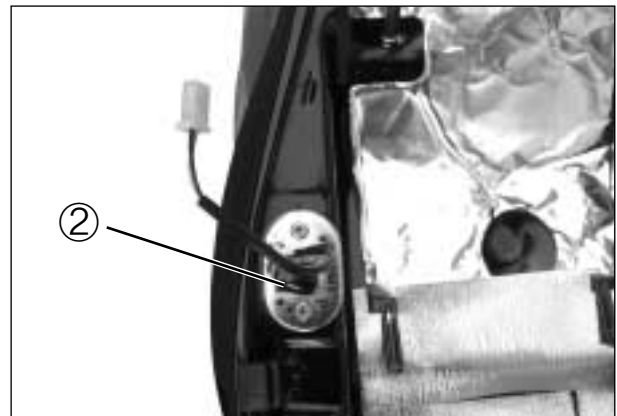

REASSEMBLY AND INSTALLATION

Reassembly and installation the fuel tank in the reverse order of removal and disassembly.

- When installing the fuel pump assembly, first tighten all the fuel pump assembly mounting bolts lightly in diagonal stages, and then tighten them in the above tightening order.

NOTE

Apply a small quantity of the **THREAD LOCK "1324"** to the thread portion of the fuel pump mounting bolt.

 **THREAD LOCK "1324"**



FUEL PRESSURE INSPECTION

- Remove the seat.
- Place a rag under the fuel injector hose.
- Disconnect the fuel injector hose from the fuel delivery pipe.
- Install the special tool between the fuel tank and fuel delivery pipe.

 **Fuel pump pressure gauge**
: 09915-54510

Turn the ignition switch “ON” position and check the fuel pressure.

Fuel pressure

Approx. 3.4 ~ 3.7 kgf/cm²
(333 ~ 363 kPa, 48.4 ~ 52.6 psi)

If the fuel pressure is lower than the specification, inspect the following items :

- * Fuel hose leakage
- * Clogged fuel filter
- * Pressure regulator
- * Fuel pump

If the fuel pressure is higher than the specification, inspect the following items :

- * Fuel pump check valve
- * Pressure regulator

WARNING

- Before removing the special tool, turn the ignition switch to “OFF” position and release the fuel pressure slowly.
- Gasoline is highly flammable and explosive. Keep heat, sparks and flame away.

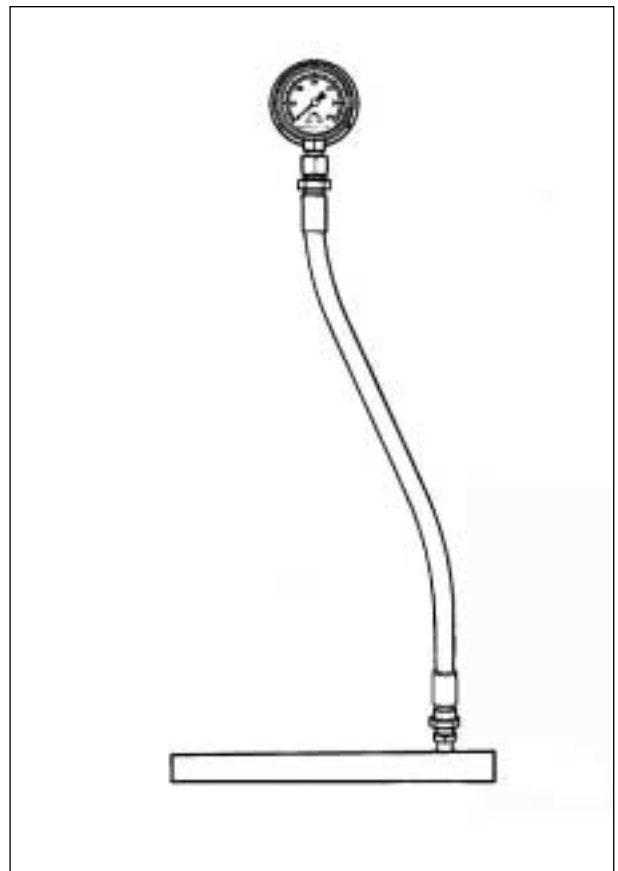

FUEL PUMP RELAY INSPECTION

Fuel pump relay is located the left side of the frame.

- Remove the frame cover.
- Remove the fuel pump relay①.

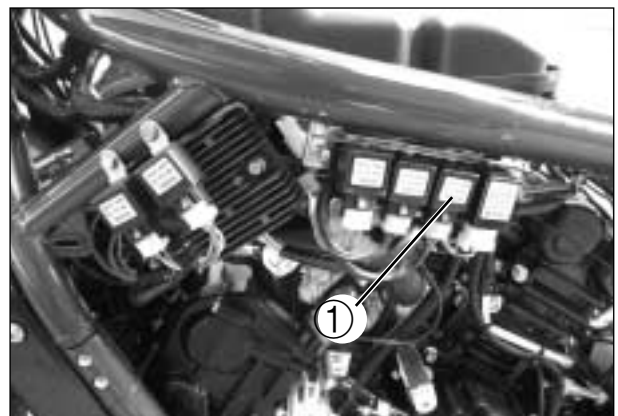

First, check the insulation between ① and ② terminals with pocket tester. Then apply 12 volts to ③ and ④ terminals, ⊕ to ③ and ⊖ to ④, and check the continuity between ① and ②.

If there is no continuity, replace it with a new one.

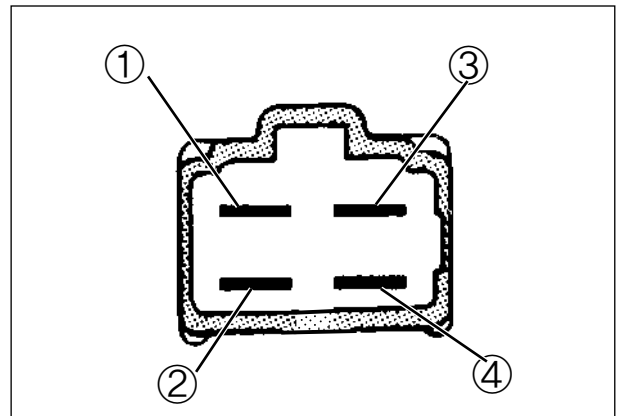

FUEL MESH FILTER INSPECTION AND CLEANING

- If the fuel mesh filter is clogged with sediment or rust, fuel will not flow smoothly and loss in engine power may result.
- Blow the fuel mesh filter with compressed air.

NOTE

If the fuel mesh filter is clogged with many sediment or rust, replace the fuel filter cartridge with a new one.

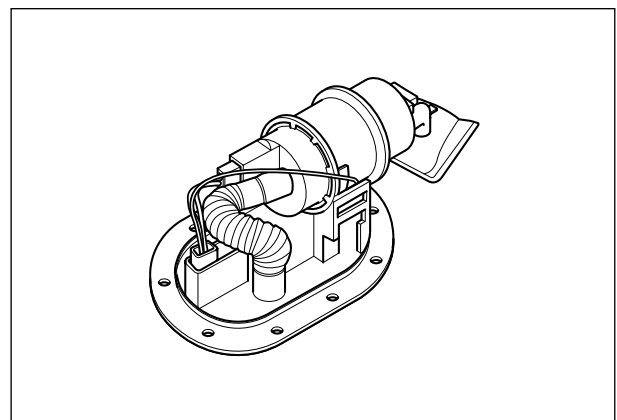

FUEL LEVEL GAUGE INSPECTION

- Measure resistance between the terminals when float is at the position instead below.

Fuel float position	Resistance between terminals
F	Approx. 90 ~ 100 Ω
1/2	Approx. 38 Ω
E	Approx. 4 ~ 10 Ω

- If the resistance measured is out of the specification, replace the gauge with a new one.
- Fuel level meter inspection.

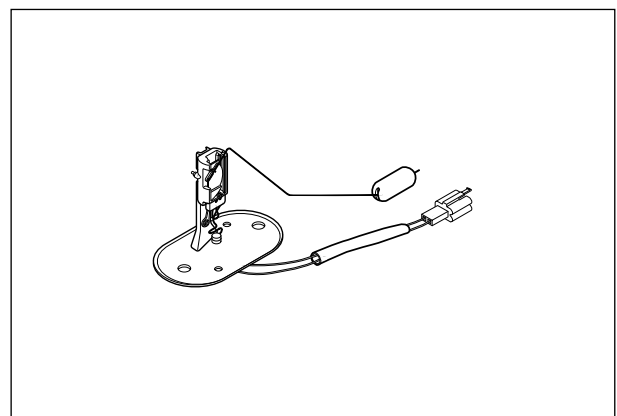

THROTTLE BODY

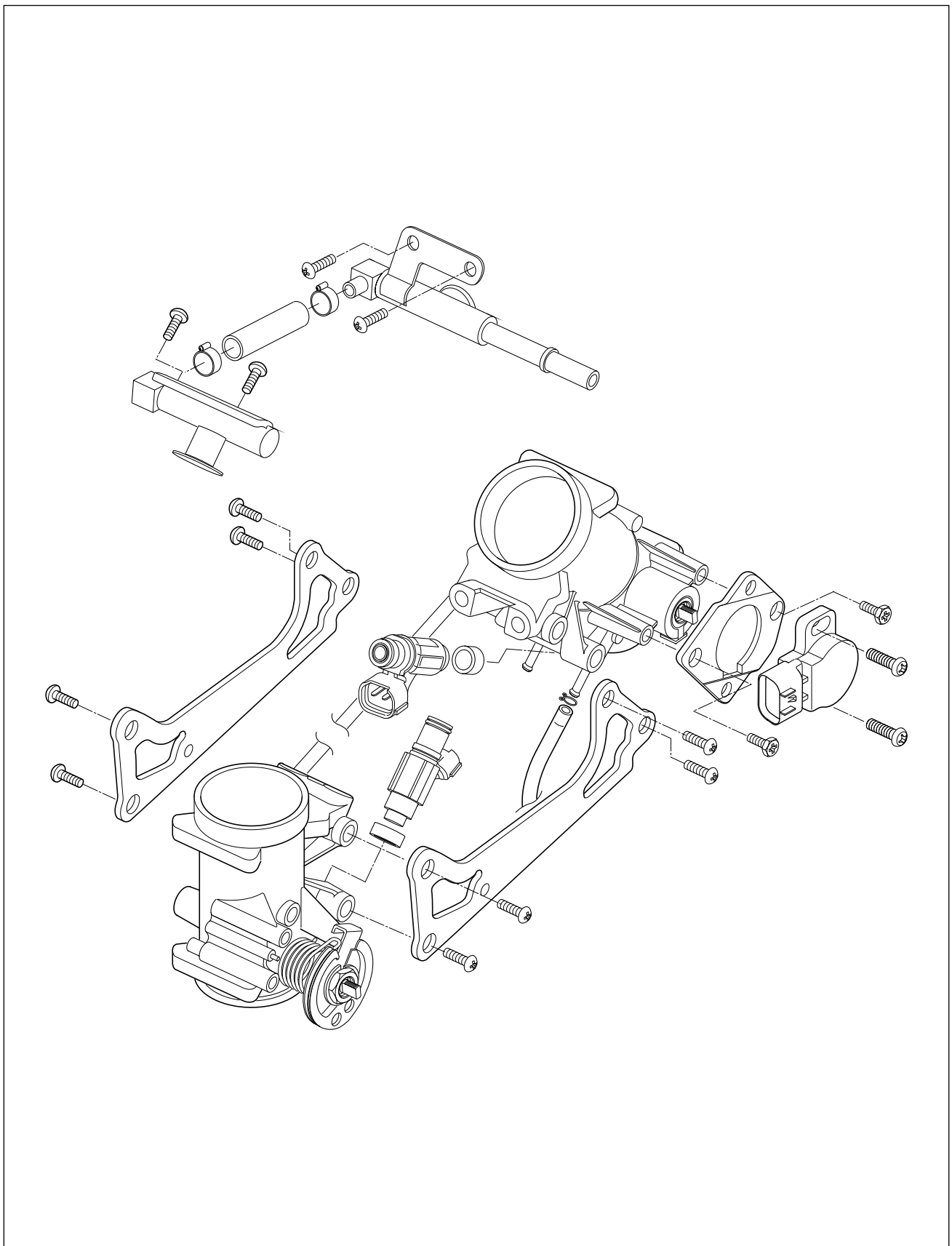

REMOVAL

- Remove the fuel tank.
- Remove the air cleaner box.
- Disconnect the fuel hose.
- Remove the all coupler to related the throttle body.



- Loosen the throttle body clamp screws.

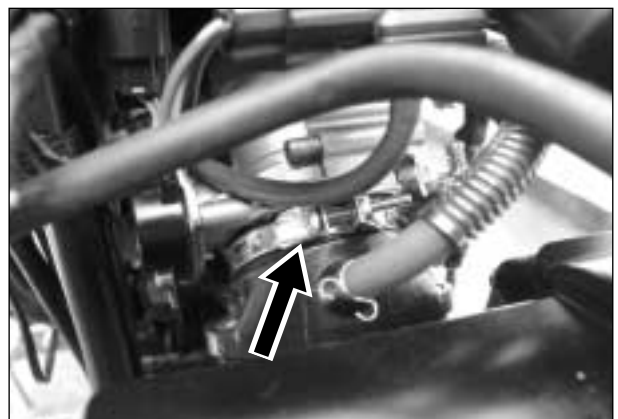
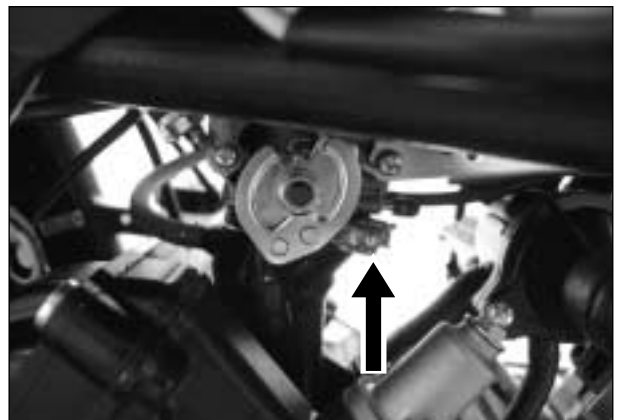

- Disconnect the throttle cables from their drum.
- Dismount the throttle body assembly.

⚠ CAUTION

- ❖ Be careful not to damage the throttle cable bracket when dismantling or remounting the throttle body assembly.
- ❖ After disconnecting the throttle cables, do not snap the throttle valve from full open to full close. It may cause damage to the throttle valve and throttle body.



CLEANING

WARNING

Some throttle body cleaning chemicals, especially dip-type soaking solutions, are very corrosive and must be handled carefully. Always follow the chemical manufacturer's instructions on proper use, handling and storage.

- Clean all passageways with a spray-type throttle body cleaner and blow dry with compressed air.

CAUTION

Do not use wire to clean passageways. Wire can damage passageways. If the components cannot be cleaned with a spray cleaner it may be necessary to use a dip-type cleaning solution and allow them to soak. Always follow the chemical manufacturer's instructions for proper use and cleaning of the throttle body components. Do not apply throttle body cleaning chemicals to the rubber and plastic materials.

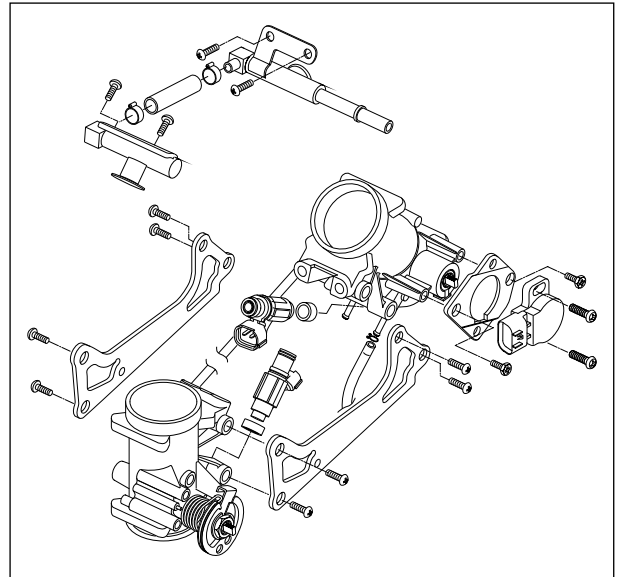

INSPECTION

- Check following items for any damage or clogging.
 - * O-ring
 - * Secondary throttle valve
 - * Throttle shaft bushing and seal
 - * Injector cushion seal
 - * Throttle valve
 - * Vacuum hose

Check fuel injector filter for evidence of dirt and contamination. If present, clean and check for presence of dirt in the fuel lines and fuel tank.

CAUTION

Never operate the idle screw ① to avoid variations of the carburetion setting.

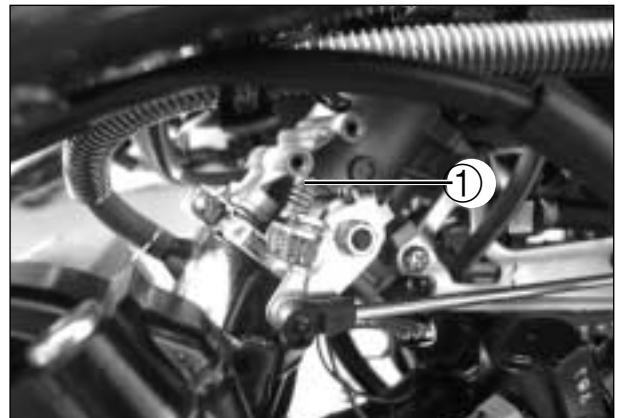

INSTALLATION

Installation is in the reverse order of removal. Pay attention to the following points :

- Connect the throttle cable to the throttle cable drum.
- Adjust the throttle cable play with the cable adjusters.



ELECTRICAL SYSTEM

CONTENTS

<i>LOCATION OF ELECTRICAL COMPONENTS</i>	60 (6-1)
<i>IGNITION SYSTEM</i>	62 (6-3)
<i>CHARGING SYSTEM</i>	63 (6-7)

LOCATION OF ELECTRICAL COMPONENTS

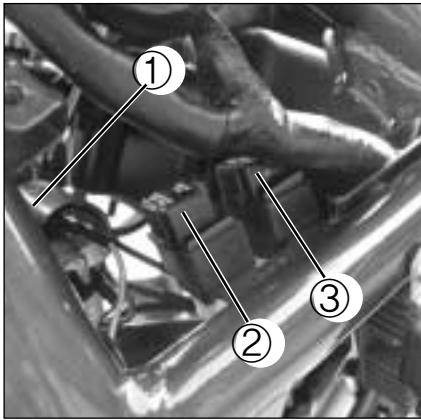

- ① Ignition coil NO.1
- ② Main fuse (30A)
- ③ Head lamp fuse (15A)

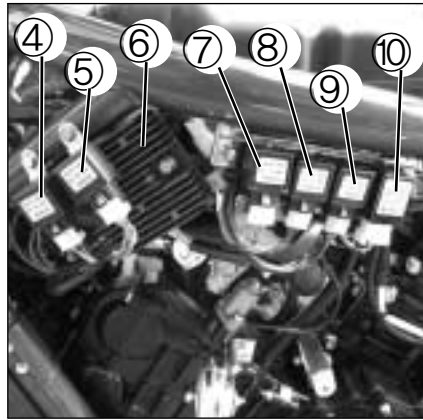

- ④ Cooling fan motor relay
- ⑤ Head lamp relay
- ⑥ Regulator / Rectifier
- ⑦ Side stand relay
- ⑧ Main relay
- ⑨ Fuel pump relay
- ⑩ Turn signal relay

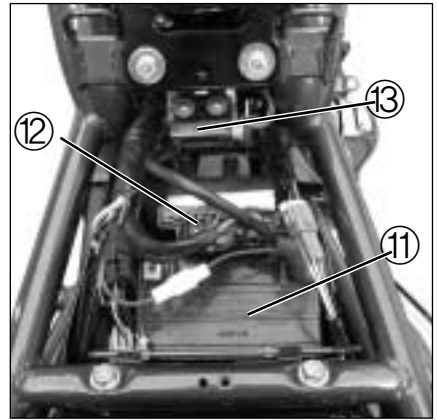

- ⑪ Battery
- ⑫ ECU
- ⑬ TO sensor

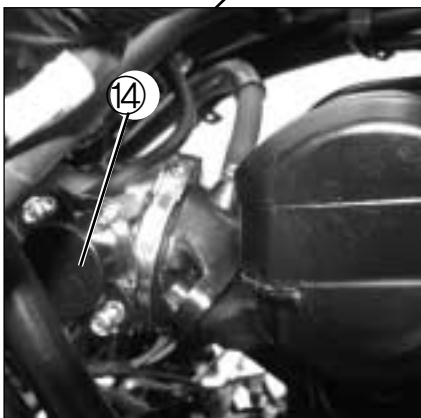
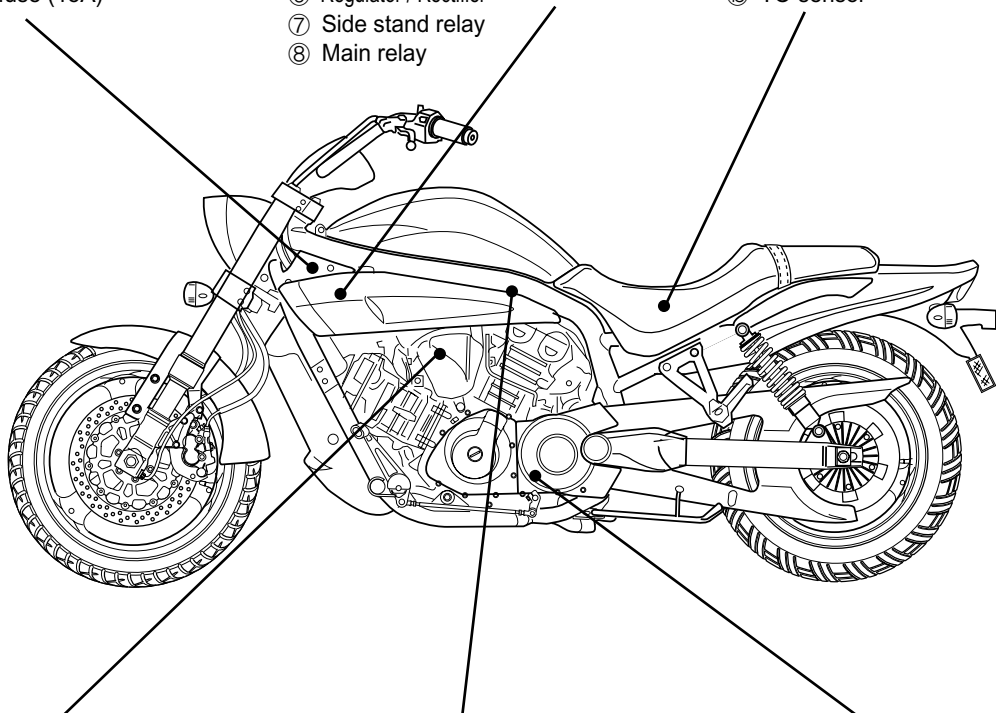

- ⑭ TP sensor

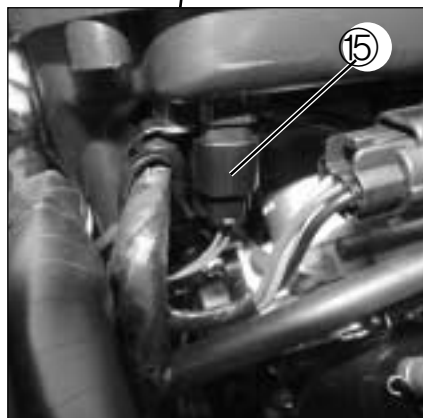

- ⑮ IAT sensor

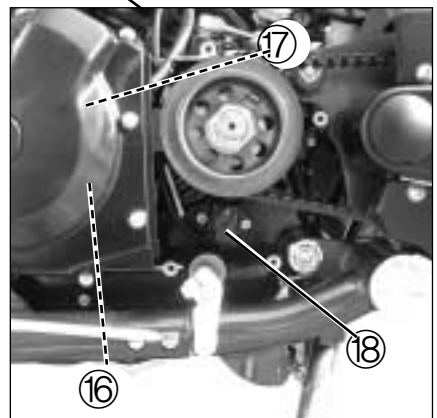

- ⑯ Magneto
- ⑰ Pick-up coil
- ⑱ GP switch

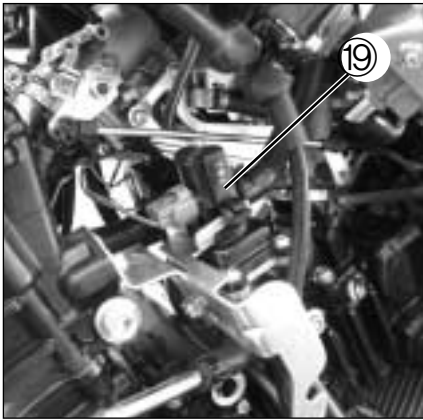

①⑨ SAV solenoid

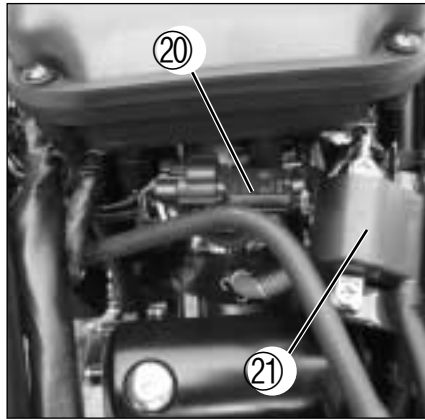

②⑩ IAP sensor NO.2
②⑪ Ignition coil NO.2

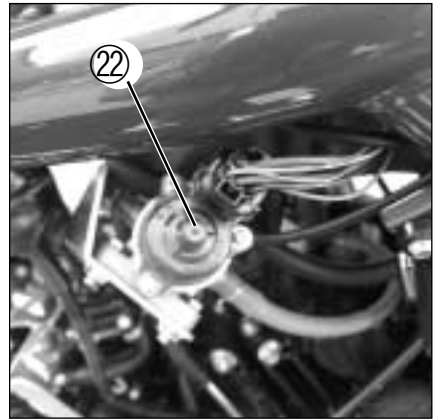

②⑫ ISC solenoid

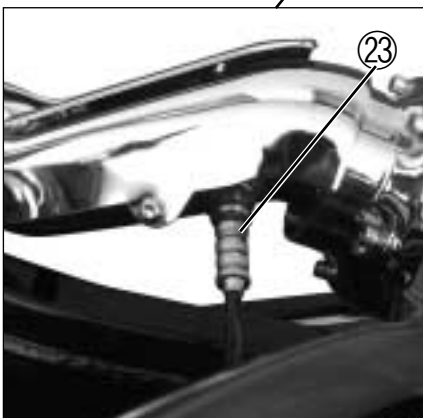
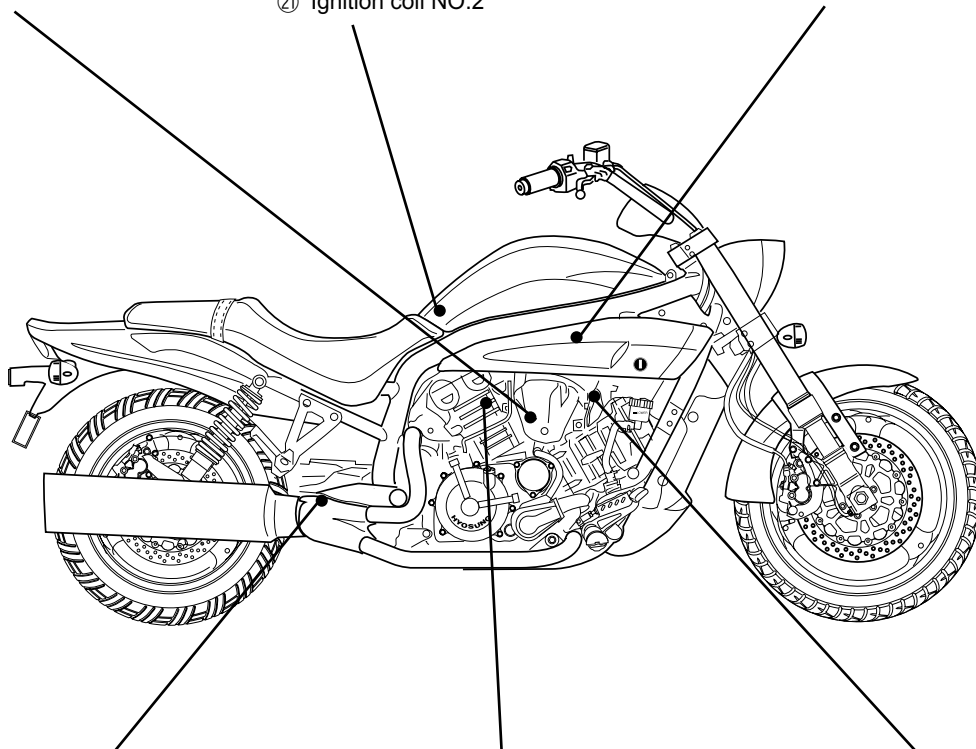

②⑬ Oxygen sensor

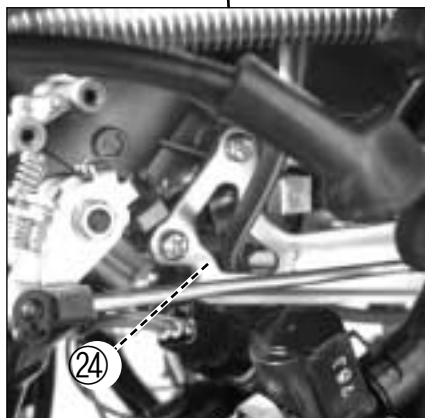

②⑭ Fuel injector NO.1

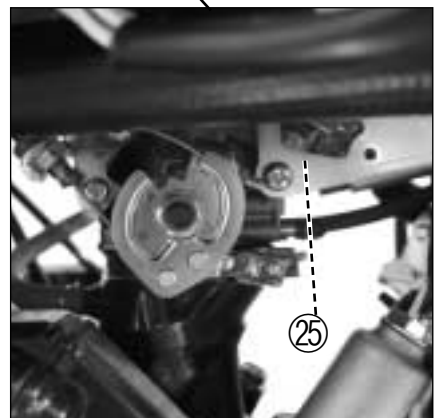

②⑮ Fuel injector NO.2

IGNITION SYSTEM

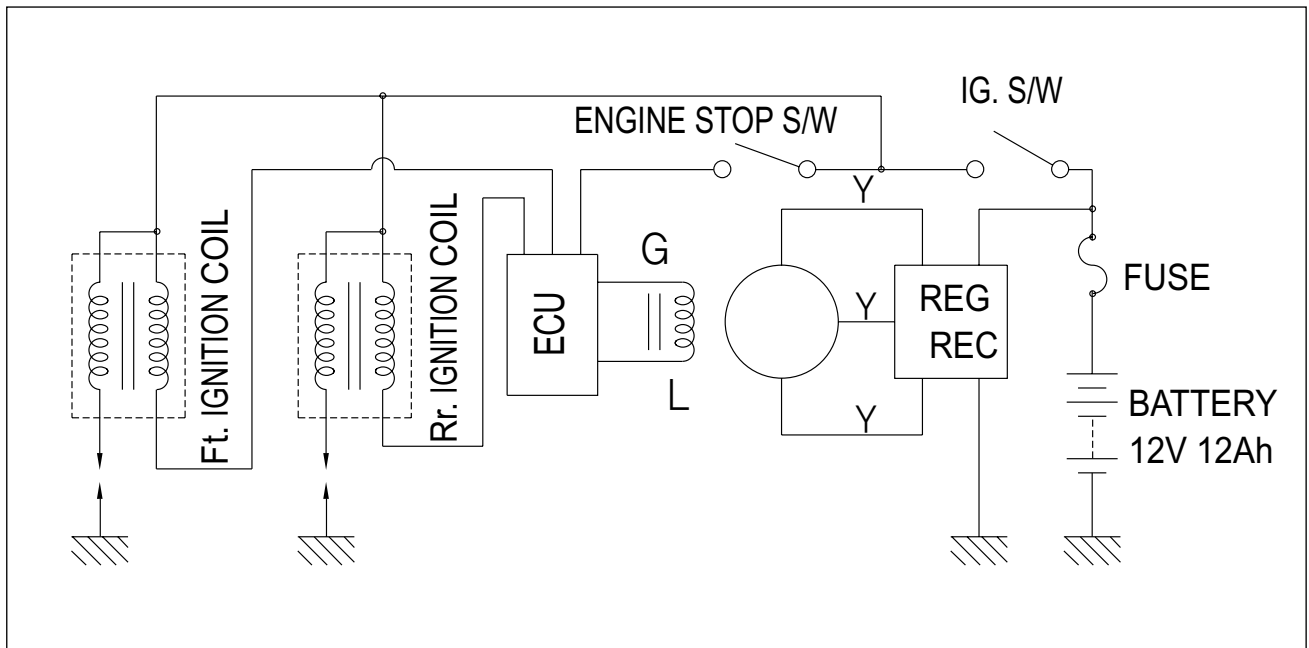

CHARGING SYSTEM

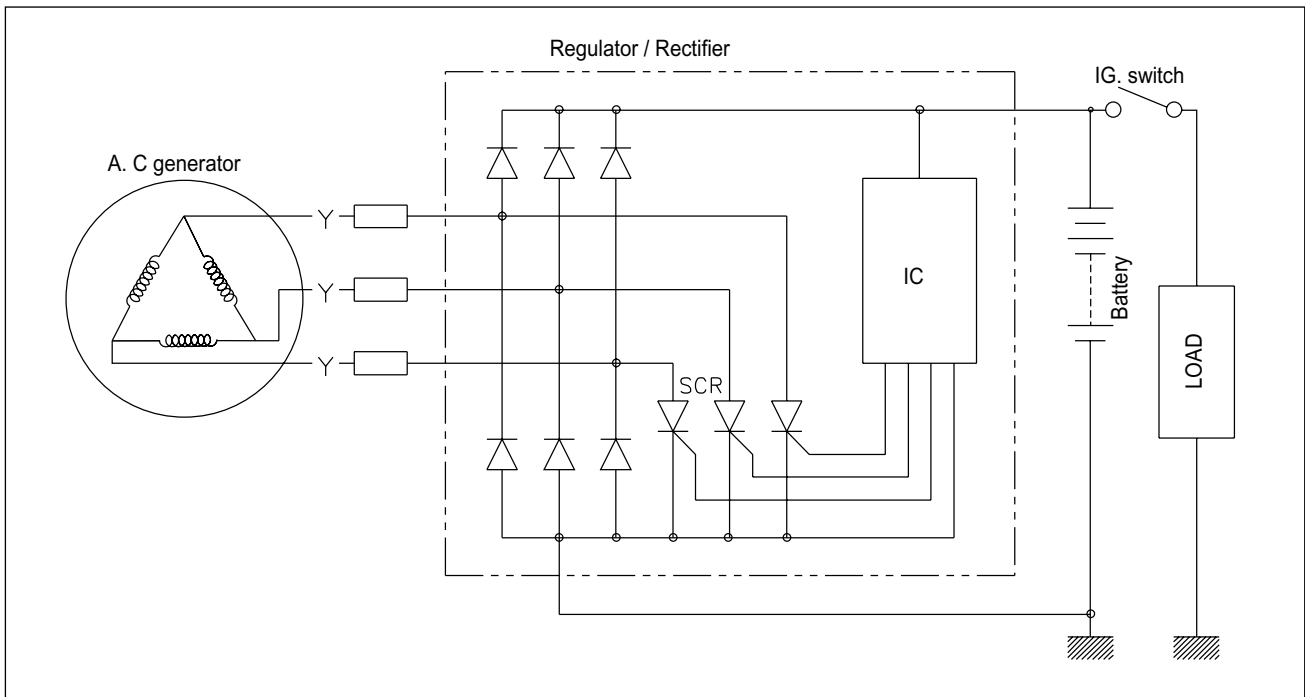

⦿ INSPECTION

▣ MAGNETO

Using the pocket tester, measure the resistance between the lead wires in the following table.

If the resistance is not within the specified value, replace the stator coil, with a new one.

Stator coil resistance	Standard
Pick-up coil	G-L 110 ~ 140 Ω
Charging coil	Y-Y 0.2 ~ 0.4 Ω

 **TOOL** Pocket Tester : 09900-25002

 **Tester knob indication : Resistance (Ω)**

CAUTION

When mounting the stator on magneto cover, apply a small quantity of THREAD LOCK "1324" to the threaded parts of screws.

 **THREAD LOCK "1324"**

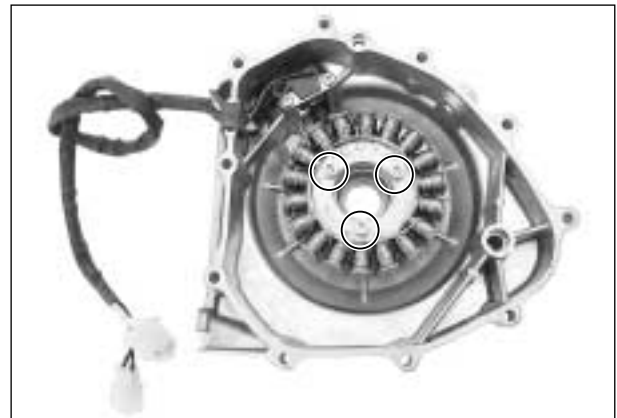

REGULATOR / RECTIFIER

- Disconnect the regulator / rectifier couplers.
 - Using the pocket tester, measure the resistance between the terminals in the following table.
- If the resistance checked is incorrect, replace the regulator / rectifier.

Unit : MΩ

		⊕ Tester probe				
⊖ Tester probe		①	②	③	④	⑤
	①		∞	∞	∞	1~2
	②	∞		∞	∞	1~2
	③	∞	∞		∞	1~2
	④	1~2	1~2	1~2		2~5
	⑤	∞	∞	∞	∞	

 **Pocket tester : 09900-25002**

 **Tester knob indication : Resistance (MΩ)**

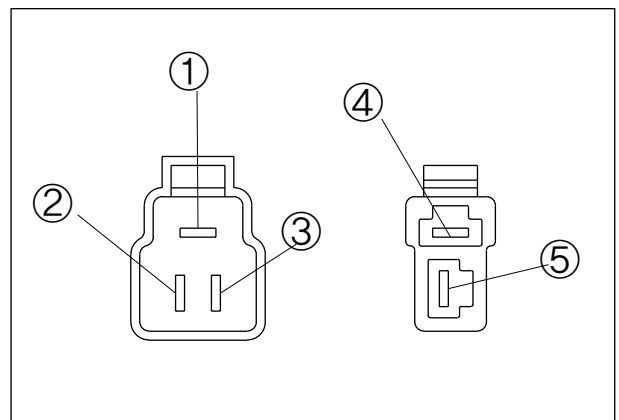
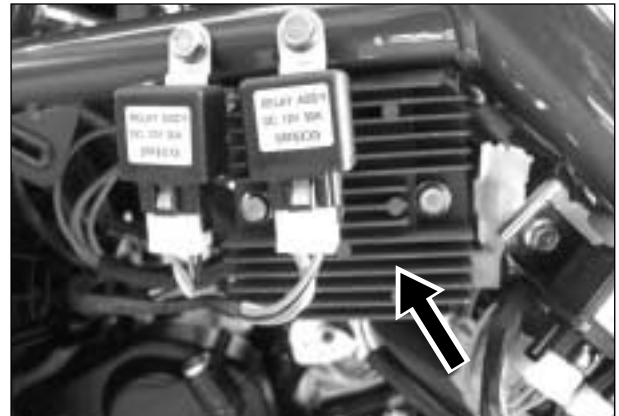

SERVICING INFORMATION

CONTENTS

TROUBLESHOOTING	66 (8-1-1)
SPECIAL TOOLS	75 (8-9)
TIGHTENING TORQUE	76 (8-12)
SERVICE DATA	77 (8-18)
WIRING DIAGRAM (<i>Aquila 650 FI</i>)	80 (8-30-1)
WIRING DIAGRAM (<i>Comet 650 FI</i>)	82 (8-30-3)
WIRING DIAGRAM (<i>Comet 650 S FI & Comet 650 R FI</i>)	84 (8-30-5)

TROUBLESHOOTING

◎ MALFUNCTION CODE AND DEFECTIVE CONDITION

MALFUNCTION CODE	DETECTED ITEM	DETECTED FAILURE CONDITION
		CHECK FOR
C00	NO FAULT	—
C12	Pick-up coil	The signal does not reach ECU for more than 2 sec. after receiving the IAP signal.
		Pick-up coil wiring and mechanical parts. (Pick-up coil, lead wire coupler connection)
C14	Throttle position sensor (TPS)	The sensor should produce following voltage. 0.2 V < sensor voltage < 4.8 V Without the above range for 5 sec. and more, C14 is indicated.
		Throttle position sensor, lead wire / coupler connection.
C15	Water temperature sensor (WTS)	The sensor voltage should be the following. 0.2 V < sensor voltage < 4.6 V Without the above range for 5 sec. and more, C15 is indicated.
		Water temperature sensor, lead wire / coupler connection.
C17 / C18	Intake air pressure sensor (IAPS), NO.1 / NO.2	The sensor should produce following voltage. 0.2 V < sensor voltage < 4.8 V Without the above range for 5 sec. and more, C17 or C18 is indicated.
		Intake air pressure sensor, lead wire / coupler connection.
C21	Intake air temperature sensor (IATS)	The sensor voltage should be the following. 0.2 V < sensor voltage < 4.6 V Without the above range for 5 sec. and more, C21 is indicated.
		Intake air temperature sensor, lead wire / coupler connection.
C22	Oxygen sensor (O ₂ S)	The oxygen sensor signal is input in ECU since then 180 sec. after the engine run. When this is the case, ECU not receive the signal, C22 is indicated.
		Oxygen sensor, lead wire / coupler connection.
C23	Tip over sensor (TOS)	The sensor voltage should be the following for more than 5 sec. after ignition switch turns "ON" position. 0.2 V < sensor voltage < 4.6 V Without the above value for 5 sec. and more, C23 is indicated.
		Tip over sensor, lead wire / coupler connection.

MALFUNCTION CODE	DETECTED ITEM	DETECTED FAILURE CONDITION
		CHECK FOR
C24 / C25	Ignition coil (IG coil), NO.1 / NO.2	Ignition signal is interrupted continuous by 32 times or more when ECU confirm ignition surge at each combustion chamber, C24 or C25 is indicated.
		Ignition coil, wiring / coupler connection, power supply from the battery.
C31	Gear position switch (GP switch)	It judges from gear position voltage, engine speed and throttle position by ECU, when the gear position voltage is 0.1 V and less.
		Gear position switch, wiring / coupler connection, gearshift cam etc.
C32 / C33	Fuel injector, NO.1 / NO.2	Injector signal is interrupted continuous by 16 times or more when ECU confirm injector running surge at each combustion chamber, C32 or C33 is indicated.
		Injector, wiring / coupler connection, power supply to the injector.
C41	Fuel pump relay	Voltage is applied continuous over 5 sec., battery voltage ≥ 5 V when fuel pump relay is "OFF" position or battery voltage < 5 V when fuel pump relay is "ON" position.
		Fuel pump relay, connecting lead wire, power source to fuel pump relay, fuel injector.

⊙ ENGINE

Complaint	Symptom and possible causes	Remedy
<p>Engine will not start or is hard to start.</p>	<p>Compression too low</p> <ol style="list-style-type: none"> 1. Tappet clearance out of adjustment. 2. Worn valve guides or poor seating of valves. 3. Mistimed valves. 4. Excessively worn piston rings. 5. Worn-down cylinder bore. 6. Starter motor cranks too slowly. 7. Poor seating of spark plugs. <p>Plug not sparking</p> <ol style="list-style-type: none"> 1. Fouled spark plugs. 2. Wet spark plugs. 3. Defective ignition coils. 4. Open or short in high-tension cord. 5. Defective pick-up coil. 6. Defective ECU. 7. Open-circuited wiring connections. <p>No fuel reaching the intake manifold</p> <ol style="list-style-type: none"> 1. Clogged fuel filter or fuel hose. 2. Defective fuel pump. 3. Defective fuel pressure regulator. 4. Defective fuel injector. 5. Defective fuel pump relay. 6. Defective ECU. 7. Open-circuited wiring connections. <p>Incorrect fuel/air mixture</p> <ol style="list-style-type: none"> 1. TP sensor out of adjustment. 2. Defective fuel pump. 3. Defective fuel pressure regulator. 4. Defective TP sensor. 5. Defective pick-up coil. 6. Defective IAP sensor. 7. Defective ECU. 8. Defective WT sensor. 9. Defective IAT sensor. 	<p>Adjust. Repair or replace. Adjust. Replace. Replace. See electrical section. Retighten.</p> <p>Clean. Clean and dry. Replace. Replace. Replace. Replace. Repair or replace.</p> <p>Clean or replace. Replace. Replace. Replace. Replace. Replace. Check and repair.</p> <p>Adjust. Replace. Replace. Replace. Replace. Replace. Replace. Replace. Replace.</p>

Complaint	Symptom and possible causes	Remedy
<p>Engine idles poorly.</p>	<ol style="list-style-type: none"> 1. Tappet clearance out of adjustment. 2. Poor seating of valves. 3. Defective valve guides. 4. Worn down camshafts. 5. Too wide spark plug gaps. 6. Defective ignition coils. 7. Defective pick-up coil. 8. Defective ECU. 9. Defective TP sensor. 10. Defective fuel pump. 11. Imbalanced throttle valve or SAV solenoid. 12. Damaged or cracked vacuum hose. 	<p>Adjust. Replace or repair. Replace. Replace. Adjust or replace. Replace. Replace. Replace. Replace. Replace. Adjust. Replace.</p>
<p>Engine stalls often</p>	<p>Incorrect fuel / air mixture</p> <ol style="list-style-type: none"> 1. Defective IAP sensor or circuit. 2. Clogged fuel filter. 3. Defective fuel pump. 4. Defective fuel pressure regulator. 5. Defective WT sensor. 6. Defective thermostat. 7. Defective IAT sensor. 8. Damaged or cracked vacuum hose. <p>Fuel injector improperly operating</p> <ol style="list-style-type: none"> 1. Defective fuel injectors. 2. No injection signal from ECU. 3. Open or short circuited wiring connection. 4. Defective battery or low battery voltage. <p>Control circuit or sensor improperly operating</p> <ol style="list-style-type: none"> 1. Defective ECU. 2. Defective fuel pressure regulator. 3. Defective TP sensor. 4. Defective IAT sensor. 5. Defective pick-up coil. 6. Defective WT sensor. 7. Defective fuel pump relay. <p>Engine internal parts improperly operating</p> <ol style="list-style-type: none"> 1. Fouled spark plugs. 2. Defective pick-up coil or ECU. 3. Clogged fuel hose. 4. Tappet clearance out of adjustment. 	<p>Repair or replace. Clean or replace. Replace. Replace. Replace. Replace. Replace. Replace. Replace.</p> <p>Replace. Repair or replace. Repair or replace. Replace or recharge.</p> <p>Replace. Replace. Replace. Replace. Replace. Replace.</p> <p>Clean. Replace. Clean. Adjust.</p>

8-1-5 SERVICING INFORMATION

Complaint	Symptom and possible causes	Remedy
<p>Noisy engine.</p>	<p>Excessive valve chatter</p> <ol style="list-style-type: none"> 1. Too large tappet clearance. 2. Weakened or broken valve springs. 3. Worn tappet or cam surface. 4. Worn and burnt camshaft journal. 	<p>Adjust. Replace. Replace. Replace.</p>
	<p>Noise seems to come from piston</p> <ol style="list-style-type: none"> 1. Worn down pistons or cylinders. 2. Combustion chambers fouled with carbon. 3. Worn piston pins or piston pin bore. 4. Worn piston rings or ring grooves. 	<p>Replace. Clean. Replace. Replace.</p>
	<p>Noise seems to come from cam chain</p> <ol style="list-style-type: none"> 1. Stretched chain. 2. Worn sprockets. 3. Tension adjuster not working. 	<p>Replace. Replace. Repair or replace.</p>
	<p>Noise seems to come from clutch</p> <ol style="list-style-type: none"> 1. Worn splines of countershaft or hub. 2. Worn teeth of clutch plates. 3. Distorted clutch plates, driven and drive. 4. Worn clutch release bearing. 5. Weakened clutch dampers. 	<p>Replace. Replace. Replace. Replace. Replace the primary driven gear.</p>
	<p>Noise seems to come from crankshaft</p> <ol style="list-style-type: none"> 1. Rattling bearings due to wear. 2. Worn and burnt big-end bearings. 3. Worn and burnt journal bearings. 	<p>Replace. Replace. Replace.</p>
	<p>Noise seems to come from transmission</p> <ol style="list-style-type: none"> 1. Worn or rubbing gears. 2. Worn splines. 3. Worn bearings. 4. Worn or rubbing primary gears. 	<p>Replace. Replace. Replace. Replace.</p>
	<p>Noise seems to come from water pump</p> <ol style="list-style-type: none"> 1. Too much play on pump shaft bearing. 2. Worn or damaged impeller shaft. 3. Worn or damaged mechanical seal. 4. Contact between pump case and impeller. 	<p>Replace. Replace. Replace. Replace.</p>

Complaint	Symptom and possible causes	Remedy
<p>Engine runs poorly in high speed range.</p>	<p>Defective engine internal / electrical parts</p> <ol style="list-style-type: none"> 1. Weakened valve springs. 2. Worn camshafts. 3. Valve timing out of adjustment. 4. Too narrow spark plug gaps. 5. Ignition not advanced sufficiently due to poorly working timing advance circuit. 6. Defective ignition coils. 7. Defective pick-up coil. 8. Defective ECU. 9. Clogged fuel hose, resulting in inadequate fuel supply to injector. 10. Defective fuel pump. 11. Defective TP sensor. 12. Defective SAV solenoid. 13. Clogged air cleaner element. <p>Defective air flow system</p> <ol style="list-style-type: none"> 1. Clogged air cleaner element. 2. Defective throttle valve. 3. Sucking air from throttle body joint. 4. Defective ECU. <p>Defective control circuit or sensor</p> <ol style="list-style-type: none"> 1. Low fuel pressure. 2. Defective TP sensor. 3. Defective IAT sensor. 4. Defective pick-up coil. 5. Defective IAP sensor. 6. Defective ECU. 7. TP sensor out of adjustment. 8. Defective SAV solenoid. 	<p>Replace. Replace. Adjust. Adjust. Replace ECU.</p> <p>Replace. Replace. Replace. Clean and prime. Replace. Replace. Replace. Clean.</p> <p>Clean or replace. Adjust or replace. Repair or replace. Replace.</p> <p>Repair or replace. Replace. Replace. Replace. Replace. Replace. Adjust. Replace.</p>

8-1-7 SERVICING INFORMATION



Complaint	Symptom and possible causes	Remedy
Engine lacks power.	<p>Defective engine internal / electrical parts</p> <ol style="list-style-type: none"> 1. Loss of tappet clearance. 2. Weakened valve springs. 3. Valve timing out of adjustment. 4. Worn piston rings or cylinders. 5. Poor seating of valves. 6. Fouled spark plugs. 7. Incorrect spark plugs. 8. Clogged injectors. 9. TP sensor out of adjustment. 10. Clogged air cleaner element. 11. Sucking air from throttle valve or vacuum hose. 12. Too much engine oil. 13. Defective fuel pump or ECU. 14. Defective pick-up coil and ignition coils. <p>Defective control circuit or sensor</p> <ol style="list-style-type: none"> 1. Low fuel pressure. 2. Defective TP sensor. 3. Defective IAT sensor. 4. Defective pick-up coil. 5. Defective IAP sensor. 6. Defective ECU. 7. TP sensor out of adjustment. 8. Defective SAV solenoid. 9. Defective GP switch. 	<p>Adjust. Replace. Adjust. Replace. Repair. Clean or replace. Adjust or replace. Clean. Adjust. Clean. Retighten or replace. Drain out excess oil. Replace. Replace.</p> <p>Repair or replace. Replace. Replace. Replace. Replace. Replace. Adjust. Replace. Replace.</p>
Engine overheats.	<p>Defective engine internal parts</p> <ol style="list-style-type: none"> 1. Heavy carbon deposit on piston crowns. 2. Not enough oil in the engine. 3. Defective oil pump or clogged oil circuit. 4. Sucking air from intake pipes. 5. Use incorrect engine oil. 6. Defective cooling system. <p>Lean fuel / air mixture</p> <ol style="list-style-type: none"> 1. Short-circuited IAP sensor / lead wire. 2. Short-circuited IAT sensor / lead wire. 3. Sucking air from intake pipe joint. 4. Defective fuel injectors. 5. Defective WT sensor. 6. Defective cooling system. <p>The other factors</p> <ol style="list-style-type: none"> 1. Ignition timing too advanced due to defective timing advance system (WT sensor, pick-up coil, GP switch and ECU). 2. Drive belt / chain is too tight. 	<p>Clean. Add oil. Replace or clean. Retighten or replace. Change. See radiator section.</p> <p>Repair or replace. Repair or replace. Repair or replace. Replace. Replace. Consult radiator section.</p> <p>Replace. Adjust.</p>

Complaint	Symptom and possible causes	Remedy
Dirty or heavy exhaust smoke.	<ol style="list-style-type: none"> 1. Too much engine oil in the engine. 2. Worn piston rings or cylinders. 3. Worn valve guides. 4. Cylinder wall scored or scuffed. 5. Worn valves stems. 6. Defective stem seals. 7. Worn side rails. 	Check with inspection window, drain out excess oil. Replace. Replace. Replace. Replace. Replace. Replace.
Slipping clutch.	<ol style="list-style-type: none"> 1. Weakened clutch springs. 2. Worn or distorted pressure plates. 3. Distorted clutch plates or pressure plates. 	Replace. Replace. Replace.
Dragging clutch.	<ol style="list-style-type: none"> 1. Some clutch springs weakened while others are not. 2. Distorted pressure plates or clutch plates. 	Replace. Replace.
Transmission will not shift.	<ol style="list-style-type: none"> 1. Broken gearshift cam. 2. Distorted gearshift forks. 3. Worn gearshift pawl. 	Replace. Replace. Replace.
Transmission will not shift back.	<ol style="list-style-type: none"> 1. Broken return spring on shift shaft. 2. Rubbing or sticky shift shaft. 3. Distorted or worn gearshift forks. 	Replace. Repair or replace Replace.
Transmission jumps out of gear.	<ol style="list-style-type: none"> 1. Worn shifting gears on driveshaft or countershaft. 2. Distorted or worn gearshift forks. 3. Weakened stopper spring on gearshift stopper. 	Replace. Replace. Replace.

⊙ ELECTRICAL

Complaint	Symptom and possible causes	Remedy
<p>No sparking or poor sparking.</p>	<ol style="list-style-type: none"> 1. Defective ignition coils or spark plug caps. 2. Defective spark plugs. 3. Defective pick-up coil. 4. Defective ECU. 5. Defective TO sensor. 6. Open-circuited wiring connections. 	<p>Replace. Replace. Replace. Replace. Replace. Check and repair.</p>
<p>Spark plug soon become fouled with carbon.</p>	<ol style="list-style-type: none"> 1. Mixture too rich. 2. Idling speed set too high. 3. Incorrect gasoline. 4. Dirty element in air cleaner. 5. Spark plugs too cold. 	<p>Inspect FI system. Adjust fast idle or throttle stop screw. Change. Clean or replace. Replace by hot type plug.</p>
<p>Spark plug become fouled too soon.</p>	<ol style="list-style-type: none"> 1. Worn piston rings. 2. Pistons or cylinders worn. 3. Excessive clearance of valve stems in valve guides. 4. Worn stem oil seal. 	<p>Replace. Replace. Replace. Replace.</p>
<p>Spark plug electrodes overheat or burn.</p>	<ol style="list-style-type: none"> 1. Spark plugs too hot. 2. The engine overheats. 3. Spark plugs loose. 4. Mixture too lean. 	<p>Replace by cold type plug. Tune up. Retighten. Adjust carburetor.</p>
<p>Magneto charge, but charging rate is below the specification.</p>	<ol style="list-style-type: none"> 1. Lead wires tend to get shorted or open-circuited or loosely connected at terminals. 2. Grounded or open-circuited stator coils of magneto. 3. Defective regulator / rectifier. 4. Defective cell plates in the battery. 	<p>Repair or retighten. Replace. Replace. Replace the battery.</p>
<p>Magneto overcharges.</p>	<ol style="list-style-type: none"> 1. Internal short - circuit in the battery. 2. Resistor element in the regulator / rectifier damaged or defective. 3. Regulator / rectifier poorly grounded. 	<p>Replace the battery. Replace. Clean and tighten ground connection.</p>
<p>Magneto does not charge.</p>	<ol style="list-style-type: none"> 1. Open - or short - circuited lead wire, or loose lead connections. 2. Short - circuited, grounded or open stator coil. 3. Short - circuited or punctured regulator / rectifier. 	<p>Repair or replace or retighten. Replace. Replace.</p>
<p>Unstable charging.</p>	<ol style="list-style-type: none"> 1. Lead wire insulation frayed due to vibration resulting in intermittent shorting. 2. Magneto internally shorted. 3. Defective regulator / rectifier. 	<p>Repair or replace Replace. Replace.</p>
<p>Starter switch is not effective.</p>	<ol style="list-style-type: none"> 1. Battery run down. 2. Defective switch contacts. 3. Brushes not seating properly on commutator in starter motor. 4. Defective starter relay / ignition interlock switch. 5. Defective main fuse. 	<p>Recharge or replace. Replace. Repair or replace. Replace. Replace.</p>

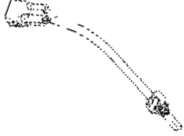
SPECIAL TOOLS

Special tools	Part Number · Part Name · Description
	09900-27000 Mode select switch
	Inspect FI system sensor.
	09915-54510 Fuel pump pressure gauge
	Measure fuel pressure of fuel pump.

TIGHTENING TORQUE

⊙ FI SYSTEM PARTS

ITEM	N · m	kg · m
Water sensor (WT sensor)	18	1.8
Fuel injector bolt	6 ~ 8	0.6 ~ 0.8

SERVICE DATA

⊙ FI SENSORS

ITEM	SPECIFICATION		NOTE
Pick-up coil resistance	110 ~ 140 Ω		
IAP sensor input voltage	4.5 ~ 5.5 V		
IAP sensor output voltage	Approx. 2.7 V at idle speed		
TP sensor input voltage	4.5 ~ 5.5 V		
TP sensor resistance	Closed	Approx. 1.28 KΩ	
	Opened	Approx. 4.37 KΩ	
TP sensor output voltage	Closed	Approx. 1.12 V	
	Opened	Approx. 4.26 V	
IAT sensor voltage	4.5 ~ 5.5 V		
IAT sensor resistance	Refer to page 39 (4-1-28)		
TO sensor voltage	0.4 ~ 1.4 V at normal condition (3.7 ~ 4.4 V at leaned more than 65°)		
TO sensor resistance	19.1 ~ 19.7 KΩ		
GP switch resistance	100 Ω ~ 2.0 KΩ		
Oxygen sensor heater voltage	Battery voltage		

⊙ THROTTLE BODY

ITEM	SPECIFICATION	NOTE
I.D. No.	HP948211	
Bore size	∅39	
Idle rpm	1,400 ~ 1,600 rpm	
Throttle cable play	0.5 ~ 1.0 mm (0.02 ~ 0.04 in)	

⊙ FUEL INJECTOR + FUEL PUMP

ITEM	SPECIFICATION	NOTE
Fuel injector resistance	11.0 ~ 13.0 Ω at 20°C (68°F)	
Fuel injector voltage	Battery voltage	
Fuel pressure	Approx. 3.4 ~ 3.7 kgf/cm ² (333 ~ 363 kPa, 48.4 ~ 52.6 psi)	

⊙ THERMOSTAT + COOLING FAN + COOLANT

ITEM	STANDARD		LIMIT
Thermostat valve operating temperature	Valve opening	88°C (190°F)	
	Valve full open	100°C (212°F)	
	Valve closing	83°C (181°F)	
Thermostat valve lift	Over 8mm (0.32 in) / 100°C (212°F)		
WT sensor voltage	4.5 ~ 5.5 V		
WT sensor resistance (To ECU)	0°C (32°F)	Approx. 5.790 KΩ	
	20°C (68°F)	Approx. 2.450 KΩ	
	40°C (104°F)	Approx. 1.148 KΩ	
	60°C (140°F)	Approx. 0.586 KΩ	
	80°C (176°F)	Approx. 0.322 KΩ	
Cooling fan thermo-switch operating temperature	OFF→ON	Approx. 95°C (203°F)	
	ON→OFF	Approx. 88°C (190°F)	
Engine coolant type	Use an antifreeze/coolant compatible with aluminum radiator, mixed with distilled water only, at the ratio of 50 : 50		
Engine coolant capacity	Reserve tank side	300 ml	
	Radiator side	370 ml	
	Engine side	480 ml	

⊙ ELECTRICAL

Unit : mm (in)

ITEM	STANDARD		NOTE
Ignition timing	BTDC 5° / 1,500 rpm		
Spark plug	Type	CR8E	
	Gap	0.7 ~ 0.8 (0.028 ~ 0.032)	
	Hot type	CR7E	
	Standard type	CR8E	
	Cold type	CR9E	
Spark performance	Over 8mm (0.32)		
Ignition coil primary peak voltage	150 V and more		
Ignition coil resistance	Primary	3.5 ~ 5.5 Ω	
	Secondary	20 ~ 31 KΩ	
Magneto coil resistance	Pick-up coil	110 ~ 140 Ω	G-L
	Charging coil	0.2 ~ 0.4 Ω	Y-Y
Magneto no-load voltage	Over 70 V / 5,000 rpm		
Battery standard charging voltage	13.5 ~ 15.0 V / 5,000 rpm		
Battery	Type	STX14-BS	
	Capacity	12V 12Ah	
	Standard electrolyte S.G.	1.320 at 20°C (68°F)	
Fuse size	Main	30A	
	Head lamp	15A	

WIRING DIAGRAM (*Aquila 650 FI*)

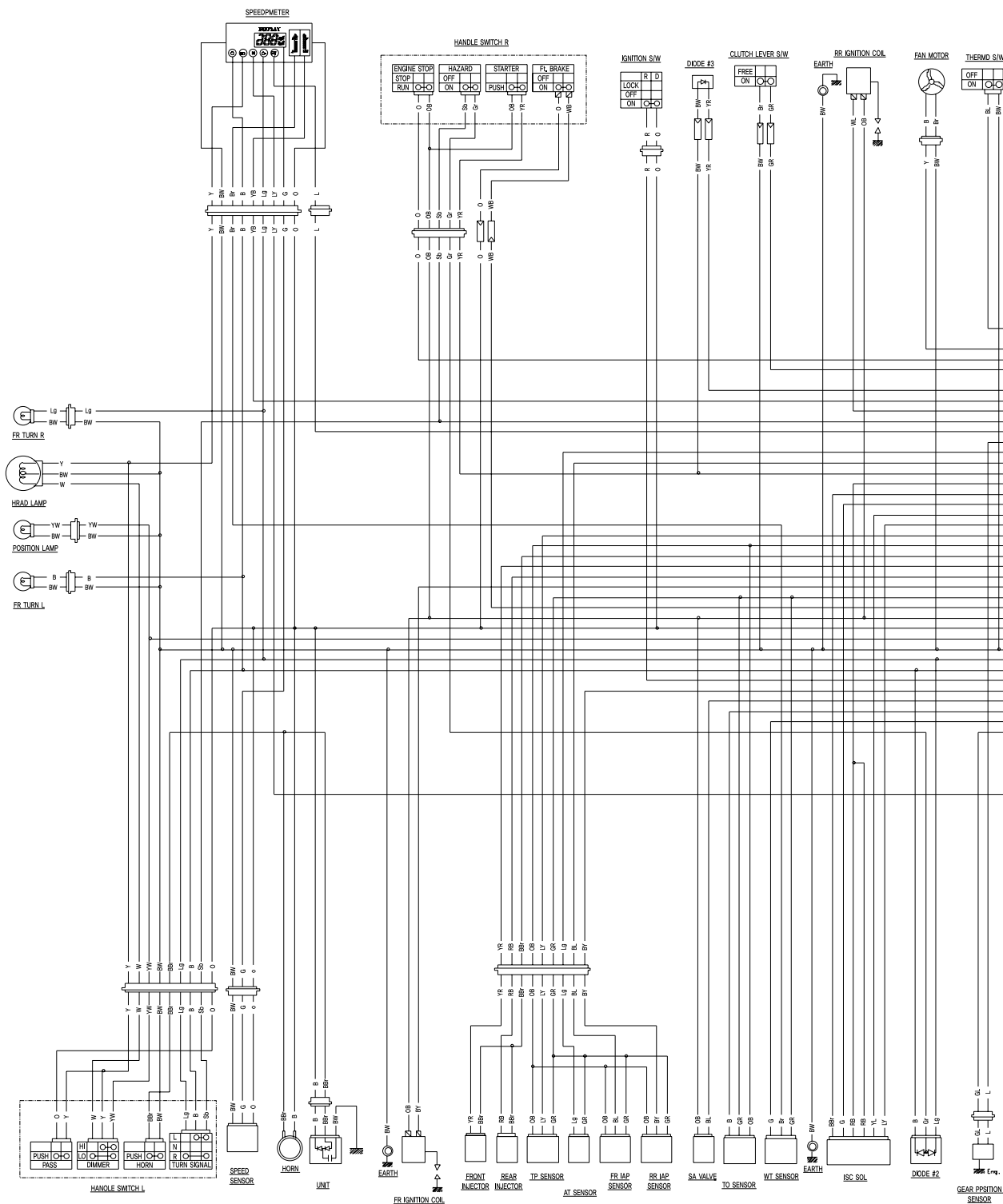

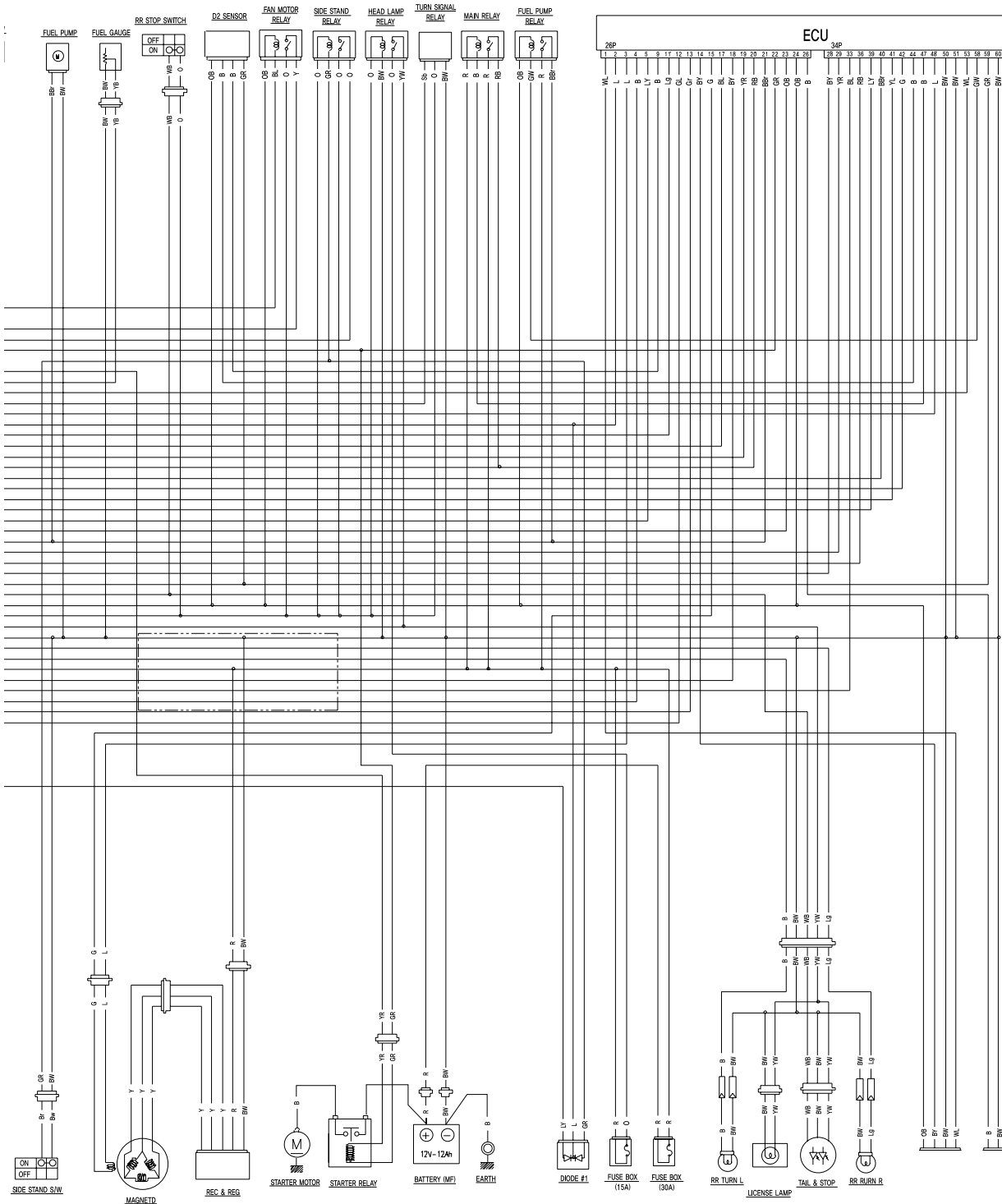

WIRING DIAGRAM (*Comet 650 FI*)

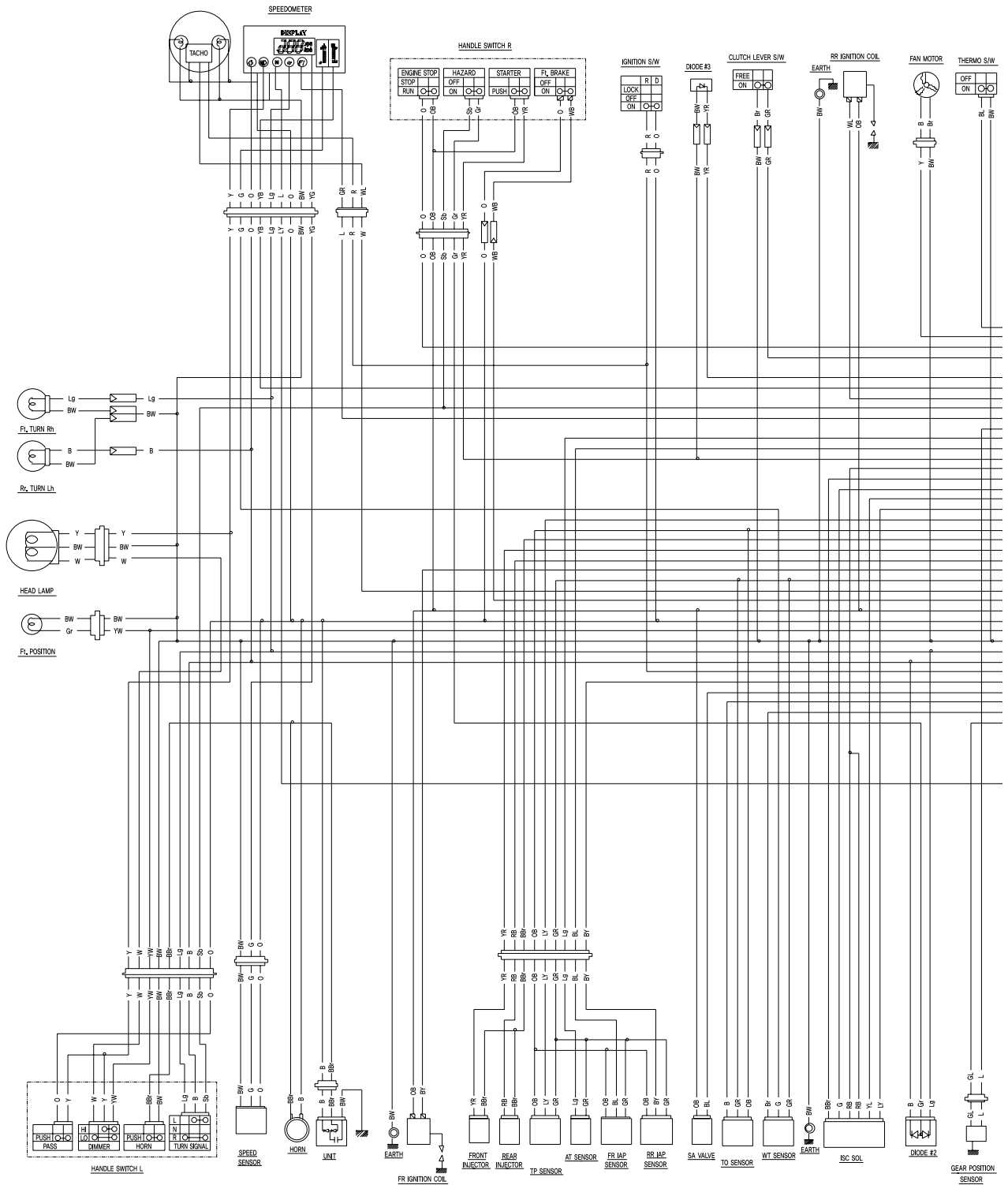

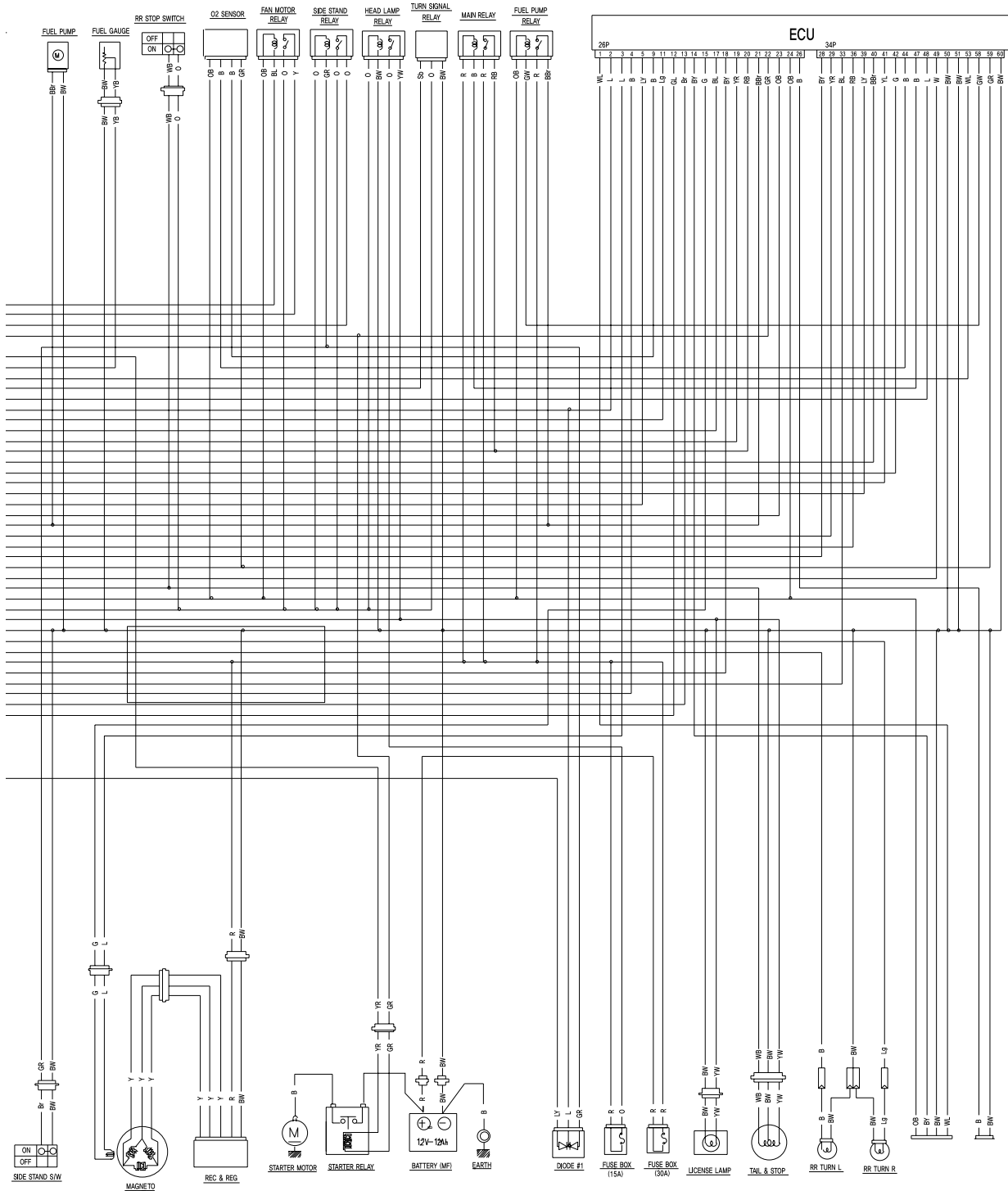

WIRING DIAGRAM (*Comet 650 S FI & Comet 650 R FI*)

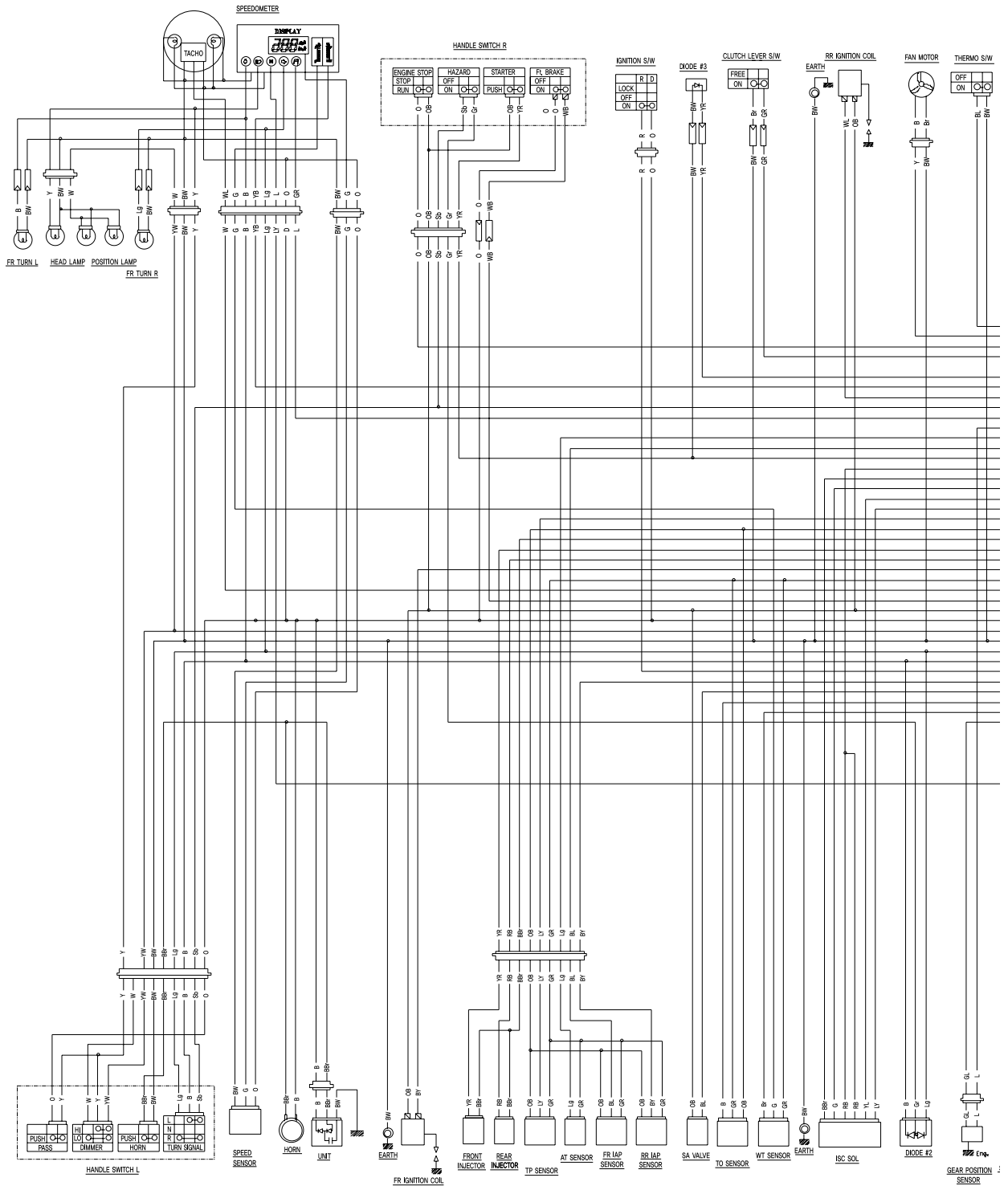

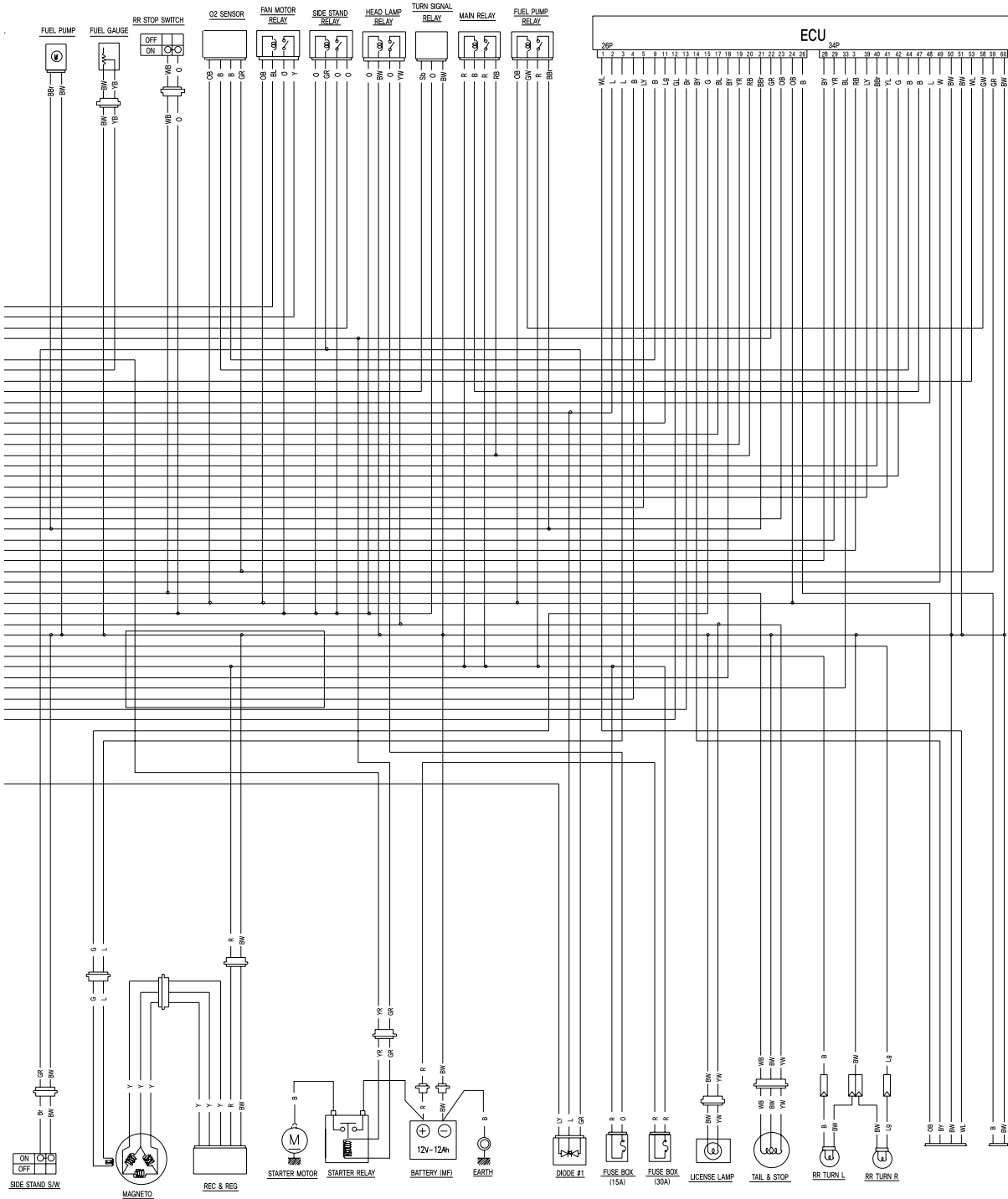

MEMO

MEMO

Prepared by



1st Ed. JUN. 2008.

Manual No. 99000-51310

Printed in Korea

S&T Motors Co., Ltd.